

Look who's talking!

Based on: W. Garret Mitchener (Mathematics, Princeton) &
Martin A. Nowak (Theoretical Biology, IAS), *Competitive
Exclusion and Coexistence of Universal Grammars*, Bulletin of
Mathematical Biology (2003), 65:67-93

presented by: Willem Zuidema
Language Evolution & Computation Research Unit &
Institute for Cell, Animal and Population Biology
University of Edinburgh, U.K.

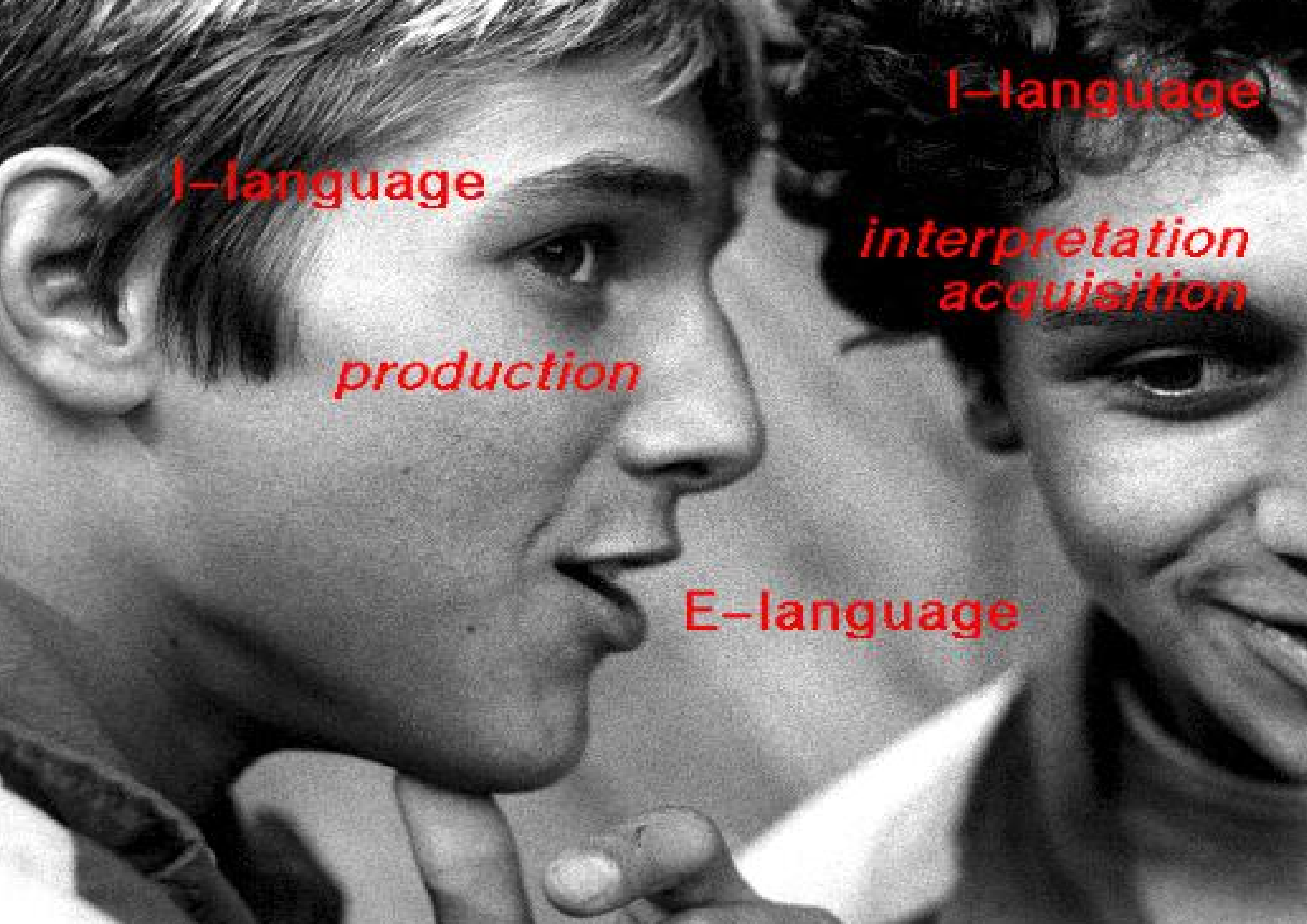



I-language

production

I-language

interpretation
acquisition

E-language

Some facts about language

Languages are surprisingly diverse...

Isolating languages: No morphological variation for tense, case or plurality; Each word typically consists of a single morpheme. E.g. Vietnamese:

Khi tôi đến nhà bạn tôi, chúng tôi bắt đầu làm bài.
when I come house friend I PLURAL I begin do lesson
“When I came to my friend’s house, we began to do lessons.”

Agglutinating languages: A word may consist of more than one morpheme; Boundaries between words are always clear-cut; A morpheme has a reasonably invariant shape. E.g. Turkish (*adam*: “man”):

	singular	plural
nominative	<i>adam</i>	<i>adam-lar</i>
accusative	<i>adam-i</i>	<i>adam-lar-i</i>
genitive	<i>adam-in</i>	<i>adam-lar-in</i>
dative	<i>adam-a</i>	<i>adam-lar-a</i>
locative	<i>adam-da</i>	<i>adam-lar-da</i>
ablative	<i>adam-dan</i>	<i>adam-lar-dan</i>

Fusional languages: No clear-cut boundary between morphemes; Expression of different categories within the same word is fused together to give a single, unsegmentable morph. E.g. Russian (*stol*: “table”, *lipa*: “lime-tree”):

	singular I	plural I	singular II	plural II
nominative	<i>stol</i>	<i>stol-y</i>	<i>lip-a</i>	<i>lip-y</i>
accusative	<i>stol</i>	<i>stol-y</i>	<i>lip-u</i>	<i>lip-y</i>
genitive	<i>stol-a</i>	<i>stol-ov</i>	<i>lip-y</i>	<i>lip</i>
dative	<i>stol-u</i>	<i>stol-am</i>	<i>lipea</i>	<i>lip-am</i>
instrumental	<i>stol-om</i>	<i>stol-ami</i>	<i>lip-oj</i>	<i>lip-ami</i>
prepositional	<i>stol-e</i>	<i>stol-ax</i>	<i>lip-e</i>	<i>lip-ax</i>

Polysynthetic languages: Many lexical morphemes combined in a single word. E.g. Chukchi (Siberia):

te- meyne- levte- peyt- erken
 great head ache 1stSINGULAR IMPERFECT
 “I have a fierce head-ache”

(Examples from Comrie, 1981)

Languages are surprisingly complex...

- (1) a. Gilligan claims that Kelly saw Campbell help Blair deceive the public.
- b. Gilligan behauptete dass Kelly Campbell Blair das Publikum belügen helfen sah.
- c. Gilligan beweert dat Kelly Campbell Blair het publiek zag helpen bedriegen.

Languages are surprisingly idiosyncratic...

- (2) a. The cow bit the horse.
b. The horse bit the cow.
c. The horse was bitten by the cow.
d. The cow was bitten by the horse.

- (3) a. Every acorn grew into an oak.
b. Every oak grew out of an acorn.
c. An oak grew out of every acorn.
d. *An acorn grew into every oak. (Gruber, 1965)
- (4) a. The **Ninja Turtle** danced while **he** ate the pizza.
b. While **he** danced the **Ninja Turtle** ate a pizza.
c. **He** danced while the **Ninja Turtle** ate the pizza.
(Crain, 1991)

Humans learn languages with surprising accuracy...



(Nim Chimpsky)

Universal Grammar

- Description of what all natural languages have in common (constraints on variation);
- Description of the initial state of a human infant's "language faculty";

What is it, who has it and how did it evolve?

(Hauser, Chomsky & Fitch, 2003, Science)

Model Details

- Large population, each member is born with one of N Universal Grammars: U_1, U_2, \dots, U_N ;
- Each member speaks one of n grammars: G_1, G_2, \dots, G_n ;
- Each UG allows one or more grammars;

- Grammars overlap with each other: $A_{i,j}$ is the probability that a sentence from G_i is understood using grammar G_j ;

- The expected communicative success is:

$$B_{i,j} = \frac{A_{i,j} + A_{j,i}}{2}$$

- $x_{j,K}$ is the fraction of the population which speaks G_j and possesses U_K ;

- $Q_{i,j,K}$ is the probability that a parent speaking G_i produces a child speaking G_j given that both have U_K ;
- The fitness (reproductive rate) is given by

$$F_j = \sum_{K=1}^N \sum_{i=1}^n B_{i,j} x_{i,K}$$

- The average fitness is:

$$\phi = \sum_{K=1}^N \sum_{j=1}^n F_j x_{i,K}$$

- The “language dynamical equation” is:

$$\dot{x}_{j,K} = \sum_{i=1}^n F_i x_{i,K} Q_{i,j,K} - \phi x_{i,K}$$

Implicit Assumptions

- i* Infinite population (no drift, no population size variation);
- ii* Preferences sender & receiver perfectly aligned/balanced;
- iii* Asexual transmission of grammars;
- iv* Continuous generation turnover;
- v* No population structure (“well-mixed”);
- vi* Finite # possible grammars;
- vii* All grammars are of equal quality (“Uniformity Hypothesis”);
- viii* Tendency to assume symmetric A and Q .

(3) Two grammars, One U.G.

$$A = \begin{pmatrix} 1 & a_{1,2} \\ a_{2,1} & 1 \end{pmatrix}$$
$$B = \frac{A + A^T}{2} = \begin{pmatrix} 1 & (a_{1,2} + a_{2,1})/2 \\ (a_{2,1} + a_{1,2})/2 & 1 \end{pmatrix}$$



$$b = \frac{a_{1,2} + a_{2,1}}{2}, \quad Q = \begin{pmatrix} q_1 & 1 - q_1 \\ 1 - q_2 & q_2 \end{pmatrix}$$

$$\begin{aligned}
\dot{x}_{j,K} &= \sum_{i=1}^n F_i x_{i,K} Q_{i,j,K} - \phi x_{i,K} \\
x_2 &= 1 - x_1 \\
\dot{x}_1 &= (1 - q_2) \\
&\quad + (-3 + b(1 + q_1 - q_2) + 2q_2)x_1 \\
&\quad + (1 - b)(3 + q_1 - q_2)x_1^2 \\
&\quad - 2(1 - b)x_1^3.
\end{aligned}$$

Bifurcation analysis

$\dot{x}_1 = (1 - q_2)$
 $+ (-3 + b(1 + q_1 - q_2) + 2q_2)x_1$
 $+ (1 - b)(3 + q_1 - q_2)x_1^2$
 $- 2(1 - b)x_1^3$

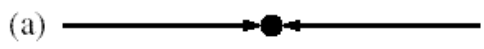
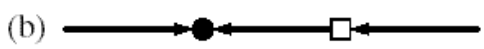
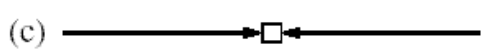
$q_1 = 0.99$
 $b = .5$

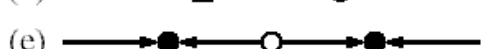
(a) 
 (b) 
 (c) 
 (d) 
 (e) 

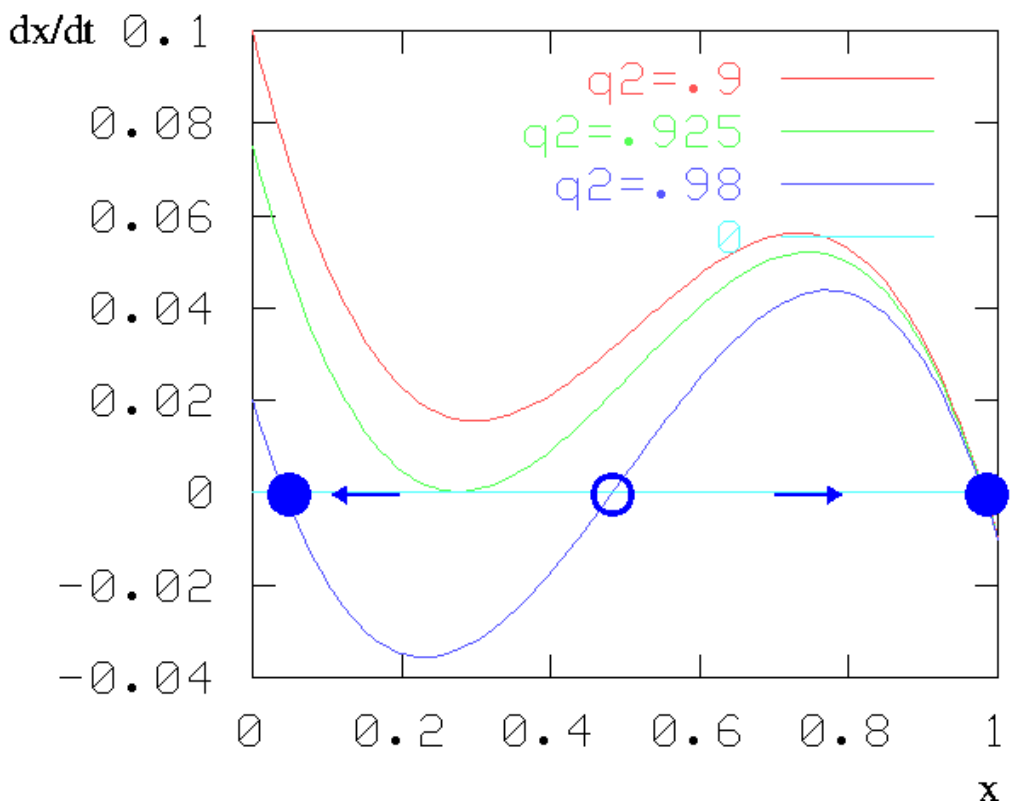

Lemma 3. (Andronov et al., 1971) Given a real-valued polynomial dynamical system $\dot{x} = f(x)$, the non-hyperbolic fixed points are exactly the roots of f of multiplicity two or more.

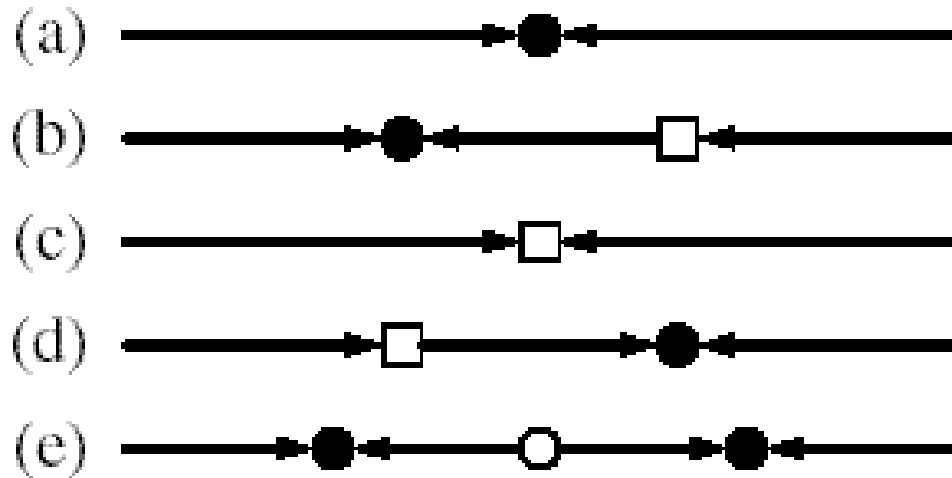

(4) Two grammars, two U.G.'s: generalists vs. specialists

$$b = \frac{a_{1,2} + a_{2,1}}{2}$$

$$Q_{i,j,1} = \begin{pmatrix} 1 & 0 \\ \# & \# \end{pmatrix}, \quad Q_{i,j,2} = \begin{pmatrix} q_1 & 1 - q_1 \\ 1 - q_2 & q_2 \end{pmatrix}$$

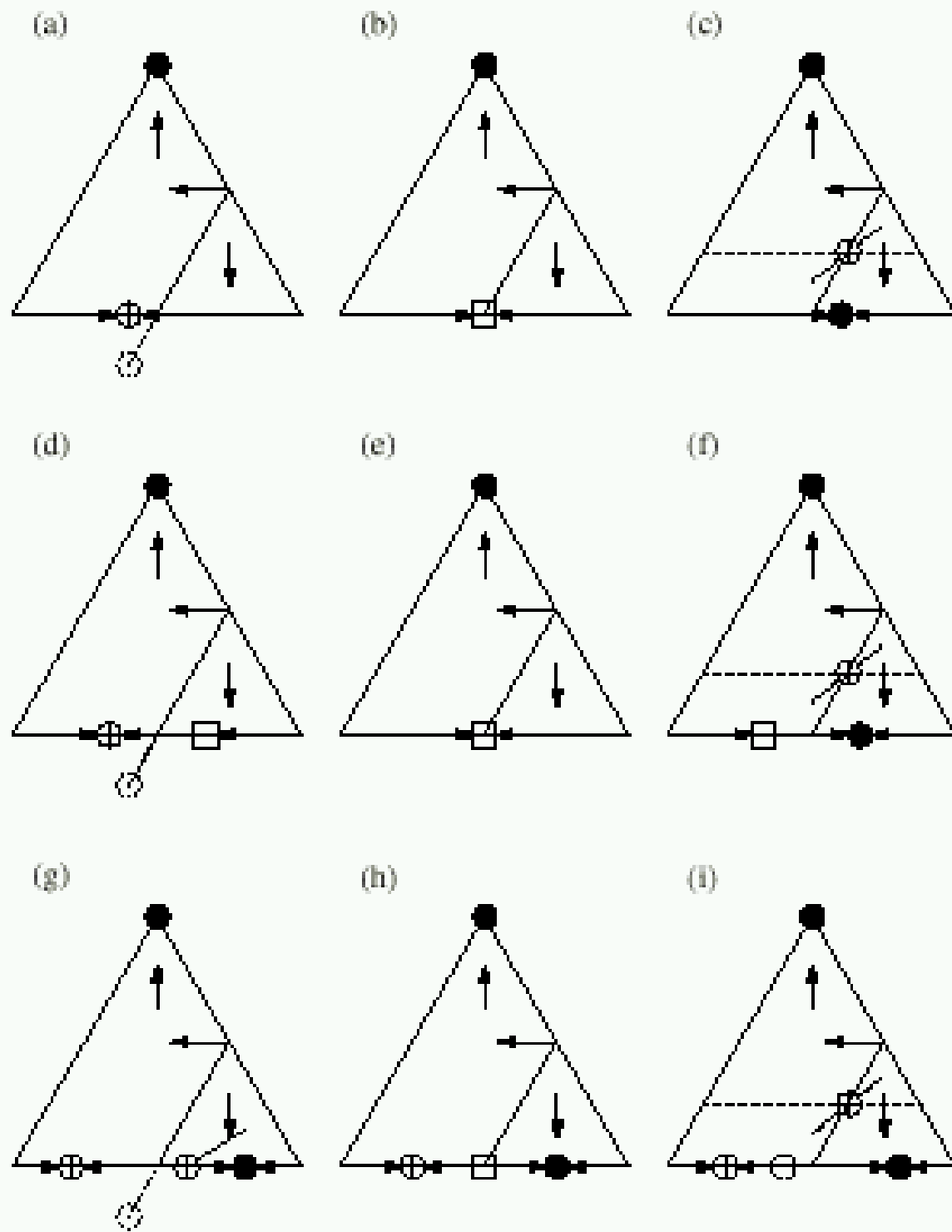
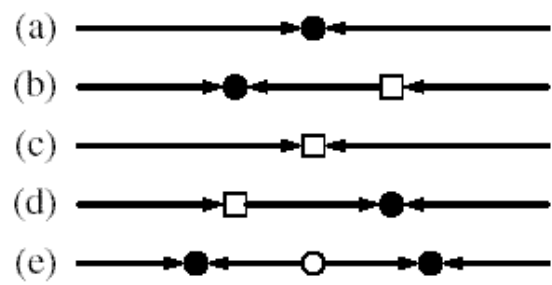
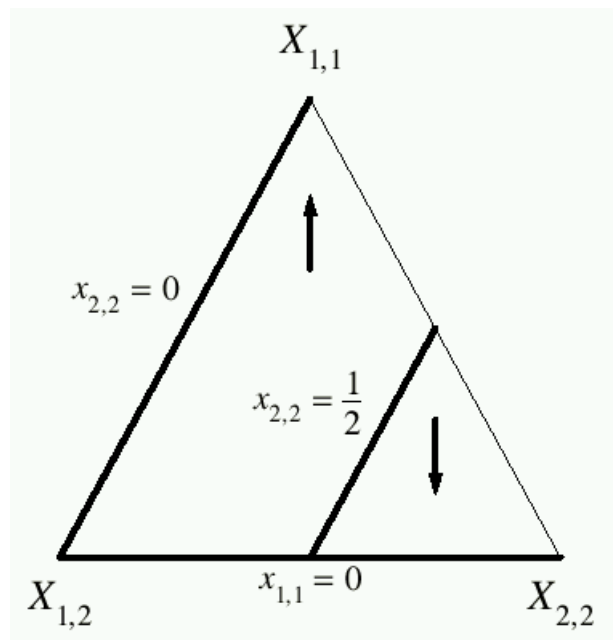

Coexistence, Competitive Exclusion

A population of U_2 people speaking G_1 can be invaded by U_1 . This is an illustration of a process by which a valuable acquired trait can become innate. This effect suggests that human UG may have once allowed many more possible grammars than it does now, and that as portions of popular grammars became innate, UG became more restrictive.

(6) Ambiguous Grammars: co-existence

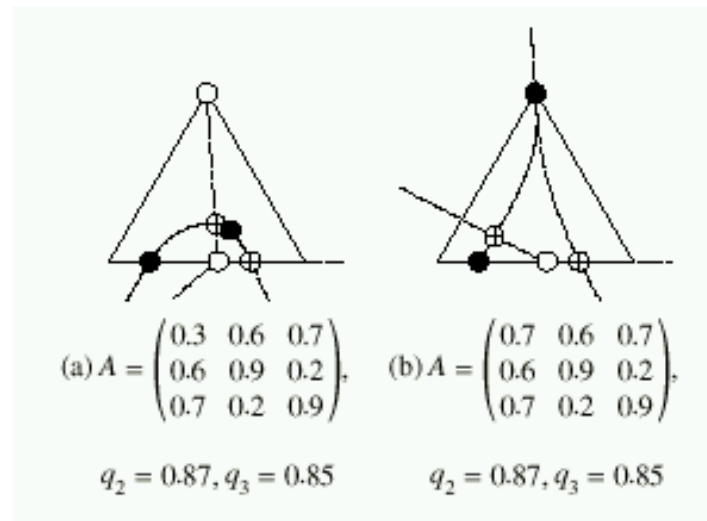
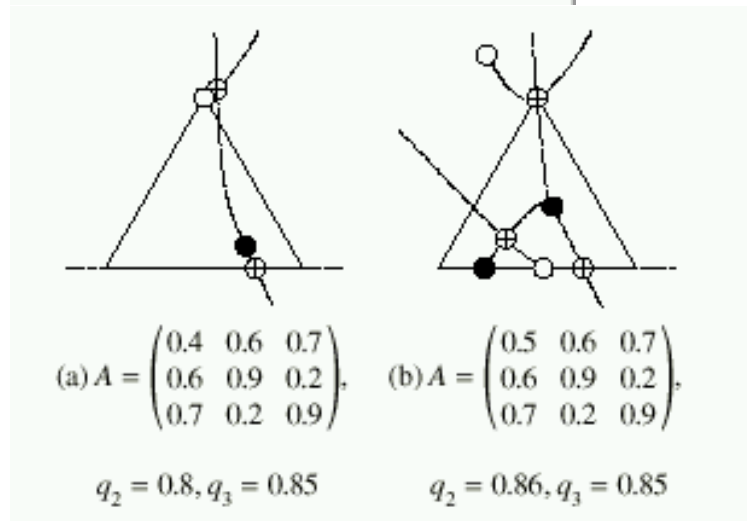
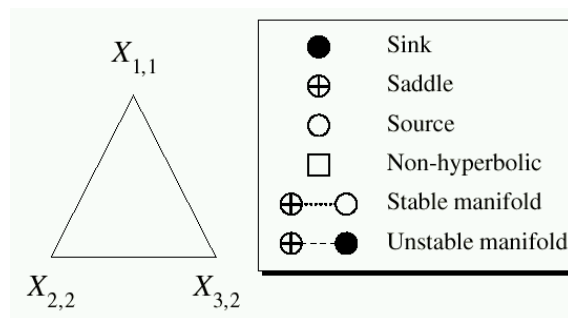

If G_1 is sufficiently ambiguous, and G_2 and G_3 are similar to it and can be learned reliably, then U_1 is unable to take over the population.

Conclusions

1. The paper gives conditions for competitive exclusion and co-existence of generalist and specialist Universal Grammars.
 - Grammar learned from single parent only;
 - “Specialist” UG’s allow single grammar only;
 - All grammars are of equal quality.

2. The model relates to models of specialists vs. generalists in ecology, and evolution of phenotypic plasticity.

- “generalists” in this model, do not benefit from being able to learn the alternative grammar.
- *“in ecology the more individuals exploit a resource the less valuable this resource becomes, but in language the more people use the same grammar the more valuable this grammar becomes.”*