

QUANTUM GROUPS AND KNOT THEORY: WEEK 47

This week we treat the first 2 sections of Chapter 6 of [1]. We give additional proofs and definitions (our paragraph numbering refers to the numbering in [1]). A good additional source for this material is [2, Chapter 1].

1. FROM RIBBON CATEGORIES TO TOPOLOGICAL INVARIANTS OF LINKS

1. Ribbon categories.

1.1. *Duality in monoidal categories.* A left duality $*$ in a strict monoidal category $\mathcal{C} = (\mathcal{C}, \otimes, I)$ is a function $V \rightarrow V^*$ on $\text{Obj}(\mathcal{C})$ together with morphisms $b_V : I \rightarrow V \otimes V^*$ and $d_V : V^* \otimes V \rightarrow I$ (called co-evaluation and evaluation respectively) such that for all V :

$$(1.1) \quad (\text{id}_V \otimes d_V)(b_V \otimes \text{id}_V) = \text{id}_V$$

$$(1.2) \quad (d_V \otimes \text{id}_{V^*})(\text{id}_{V^*} \otimes b_V) = \text{id}_{V^*}$$

Proposition 1.1. *Given a morphism $f : U \rightarrow V$ in \mathcal{C} we define its transpose $f^* : V^* \rightarrow U^*$ by*

$$(1.3) \quad f^* := (d_V \otimes \text{id}_{U^*})(\text{id}_{V^*} \otimes f \otimes \text{id}_{U^*})(\text{id}_{V^*} \otimes b_U)$$

This gives rise to a functor $$: $\mathcal{C} \rightarrow \mathcal{C}^{op}$.*

Proof. It is easy to check that $\text{id}_V^* = \text{id}_{V^*}$. Let $f : V \rightarrow W$ and $g : U \rightarrow V$. Then

$$\begin{aligned} & (fg)^* \\ &= (d_W \otimes \text{id}_{U^*})(\text{id}_{W^*} \otimes fg \otimes \text{id}_{U^*})(\text{id}_{W^*} \otimes b_U) \\ &= (d_W \otimes \text{id}_{U^*})(\text{id}_{W^*} \otimes f \otimes \text{id}_{U^*})(\text{id}_{W^*} \otimes \text{id}_V \otimes \text{id}_{U^*})(\text{id}_{W^*} \otimes g \otimes \text{id}_{U^*})(\text{id}_{W^*} \otimes b_U) \\ &= (d_W \otimes \text{id}_{U^*})(\text{id}_{W^*} \otimes f \otimes \text{id}_{U^*})(\text{id}_{W^*} \otimes \text{id}_V \otimes d_V \otimes \text{id}_{U^*}) \\ & \quad (\text{id}_{W^*} \otimes b_V \otimes \text{id}_V \otimes \text{id}_{U^*})(\text{id}_{W^*} \otimes g \otimes \text{id}_{U^*})(\text{id}_{W^*} \otimes b_U) \\ &= (d_W \otimes \text{id}_{U^*})(\text{id}_{W^*} \otimes \text{id}_W \otimes d_V \otimes \text{id}_{U^*})(\text{id}_{W^*} \otimes f \otimes \text{id}_{V^*} \otimes \text{id}_V \otimes \text{id}_{U^*}) \\ & \quad (\text{id}_{W^*} \otimes \text{id}_V \otimes \text{id}_{V^*} \otimes g \otimes \text{id}_{U^*})(\text{id}_{W^*} \otimes b_V \otimes \text{id}_U \otimes \text{id}_{U^*})(\text{id}_{W^*} \otimes b_U) \\ &= (d_W \otimes \text{id}_{U^*})(\text{id}_{W^*} \otimes \text{id}_W \otimes d_V \otimes \text{id}_{U^*})(\text{id}_{W^*} \otimes \text{id}_W \otimes \text{id}_{V^*} \otimes g \otimes \text{id}_{U^*}) \\ & \quad (\text{id}_{W^*} \otimes f \otimes \text{id}_{V^*} \otimes \text{id}_U \otimes \text{id}_{U^*})(\text{id}_{W^*} \otimes b_V \otimes \text{id}_U \otimes \text{id}_{U^*})(\text{id}_{W^*} \otimes b_U) \\ &= (d_V \otimes \text{id}_{U^*})(\text{id}_{V^*} \otimes g \otimes \text{id}_{U^*})(\text{id}_{V^*} \otimes b_U)(d_W \otimes \text{id}_{V^*})(\text{id}_{W^*} \otimes f \otimes \text{id}_{V^*})(\text{id}_{W^*} \otimes b_V) \\ &= g^* f^* \end{aligned}$$

□

Proposition 1.2. *There exists a natural family of isomorphisms $\lambda_{U,V} : V^* \otimes U^* \rightarrow (U \otimes V)^*$ (i.e. a natural isomorphisms $\lambda : \otimes \circ (* \times *) \circ \tau \rightarrow * \circ \otimes$) given by*

$$(1.4) \quad \lambda_{U,V} := (d_V \otimes \text{id}_{(U \otimes V)^*})(\text{id}_{V^*} \otimes d_U \otimes \text{id}_V \otimes \text{id}_{(U \otimes V)^*})(\text{id}_{V^*} \otimes \text{id}_{U^*} \otimes b_{U \otimes V})$$

with inverse $\mu_{U,V} : (U \otimes V)^* \rightarrow V^* \otimes U^*$ given by

$$(1.5) \quad \mu_{U,V} := (d_{U \otimes V} \otimes \text{id}_{V^*} \otimes \text{id}_{U^*})(\text{id}_{(U \otimes V)^*} \otimes \text{id}_U \otimes b_V \otimes \text{id}_{U^*})(\text{id}_{(U \otimes V)^*} \otimes b_U)$$

Proof. We (unhappily) compute

$$\begin{aligned} & \lambda_{U,V} \mu_{U,V} \\ &= (d_V \otimes \text{id}_{(U \otimes V)^*})(\text{id}_{V^*} \otimes d_U \otimes \text{id}_V \otimes \text{id}_{(U \otimes V)^*})(\text{id}_{V^*} \otimes \text{id}_{U^*} \otimes b_{U \otimes V}) \\ & \quad (d_{U \otimes V} \otimes \text{id}_{V^*} \otimes \text{id}_{U^*})(\text{id}_{(U \otimes V)^*} \otimes \text{id}_U \otimes b_V \otimes \text{id}_{U^*})(\text{id}_{(U \otimes V)^*} \otimes b_U) \\ &= (d_V \otimes \text{id}_{(U \otimes V)^*})(\text{id}_{V^*} \otimes d_U \otimes \text{id}_V \otimes \text{id}_{(U \otimes V)^*})(\text{id}_I \otimes \text{id}_{V^*} \otimes \text{id}_{U^*} \otimes b_{U \otimes V}) \\ & \quad (d_{U \otimes V} \otimes \text{id}_{V^*} \otimes \text{id}_{U^*} \otimes \text{id}_I)(\text{id}_{(U \otimes V)^*} \otimes \text{id}_U \otimes b_V \otimes \text{id}_{U^*})(\text{id}_{(U \otimes V)^*} \otimes b_U) \\ &= (d_V \otimes \text{id}_{(U \otimes V)^*})(\text{id}_{V^*} \otimes d_U \otimes \text{id}_V \otimes \text{id}_{(U \otimes V)^*})(d_{U \otimes V} \otimes \text{id}_{V^*} \otimes \text{id}_{U^*} \otimes \text{id}_{U \otimes V} \otimes \text{id}_{(U \otimes V)^*}) \\ & \quad (\text{id}_{(U \otimes V)^*} \otimes \text{id}_{U \otimes V} \otimes \text{id}_{V^*} \otimes \text{id}_{U^*} \otimes b_{U \otimes V})(\text{id}_{(U \otimes V)^*} \otimes \text{id}_U \otimes b_V \otimes \text{id}_{U^*})(\text{id}_{(U \otimes V)^*} \otimes b_U) \\ &= (d_{U \otimes V} \otimes \text{id}_{(U \otimes V)^*})(\text{id}_{(U \otimes V)^*} \otimes \text{id}_U \otimes \text{id}_V \otimes d_V \otimes \text{id}_{(U \otimes V)^*}) \\ & \quad (\text{id}_{(U \otimes V)^*} \otimes \text{id}_U \otimes \text{id}_V \otimes \text{id}_{V^*} \otimes d_U \otimes \text{id}_V \otimes \text{id}_{(U \otimes V)^*}) \\ & \quad (\text{id}_{(U \otimes V)^*} \otimes \text{id}_U \otimes b_V \otimes \text{id}_{U^*} \otimes \text{id}_U \otimes \text{id}_V \otimes \text{id}_{(U \otimes V)^*}) \\ & \quad (\text{id}_{(U \otimes V)^*} \otimes b_U \otimes \text{id}_U \otimes \text{id}_V \otimes \text{id}_{(U \otimes V)^*})(\text{id}_{(U \otimes V)^*} \otimes b_{U \otimes V}) \\ &= (d_{U \otimes V} \otimes \text{id}_{(U \otimes V)^*})(\text{id}_{(U \otimes V)^*} \otimes \text{id}_U \otimes \text{id}_V \otimes d_V \otimes \text{id}_{(U \otimes V)^*}) \\ & \quad (\text{id}_{(U \otimes V)^*} \otimes \text{id}_U \otimes b_V \otimes \text{id}_V \otimes \text{id}_{(U \otimes V)^*}) \\ & \quad (\text{id}_{(U \otimes V)^*} \otimes \text{id}_U \otimes d_U \otimes \text{id}_V \otimes \text{id}_{(U \otimes V)^*}) \\ & \quad (\text{id}_{(U \otimes V)^*} \otimes b_U \otimes \text{id}_U \otimes \text{id}_V \otimes \text{id}_{(U \otimes V)^*})(\text{id}_{(U \otimes V)^*} \otimes b_{U \otimes V}) \\ &= (d_{U \otimes V} \otimes \text{id}_{(U \otimes V)^*})(\text{id}_{(U \otimes V)^*} \otimes b_{U \otimes V}) \\ &= \text{id}_{(U \otimes V)^*} \end{aligned}$$

In a similar fashion one shows that $\mu_{U,V} \lambda_{U,V} = \text{id}_{V^* \otimes U^*}$.

The naturality of $\lambda_{U,V}$ and $\mu_{U,V}$ can be shown as well, but we will postpone this until we have more efficient tools at our disposal (see Remark 2.13). \square

The above computations show, if anything, that we are in desperate need of a more efficient language to do calculations in monoidal categories. Please don't panic! We will soon develop a powerful graphical notation for computations such as the ones above (and much worse cases...).

Exercise (a). *Show that*

$$(\text{id}_{U \otimes V} \otimes \mu_{U,V})b_{U \otimes V} = (\text{id}_U \otimes b_V \otimes \text{id}_{U^*})b_U$$

and

$$d_{U \otimes V}(\lambda_{U,V} \otimes \text{id}_{U \otimes V}) = d_V(\text{id}_{V^*} \otimes d_U \otimes \text{id}_V)$$

1.2. *Twist in braided monoidal categories.*

1.3. *Ribbon categories.* A ribbon category is a strict monoidal category \mathcal{C} together with braiding, a twist θ , and a (left) duality $(*, b, d)$ which is compatible with the braiding and twist in the sense that it satisfies for any object V in \mathcal{C} :

$$(1.6) \quad (\theta_V \otimes \text{id}_{V^*})b_V = (\text{id}_V \otimes \theta_{V^*})b_V$$

This compatibility is equivalent to saying that $(\theta_V)^* = \theta_{V^*}$. Indeed, suppose that $(\theta_V)^* = \theta_{V^*}$. Then

$$\begin{aligned} & (\theta_V \otimes \text{id}_{V^*})b_V \\ &= (\text{id}_V \otimes d_V \otimes \text{id}_{V^*})(b_V \otimes \text{id}_V \otimes \text{id}_{V^*})(\theta_V \otimes \text{id}_{V^*})b_V \\ &= (\text{id}_V \otimes d_V \otimes \text{id}_{V^*})(\text{id}_V \otimes \text{id}_{V^*} \otimes \theta_V \otimes \text{id}_{V^*})(b_V \otimes \text{id}_V \otimes \text{id}_{V^*})b_V \\ &= (\text{id}_V \otimes d_V \otimes \text{id}_{V^*})(\text{id}_V \otimes \text{id}_{V^*} \otimes \theta_V \otimes \text{id}_{V^*})(\text{id}_V \otimes \text{id}_{V^*} \otimes b_V)b_V \\ &= (\text{id}_V \otimes (\theta_V)^*)b_V \\ &= (\text{id}_V \otimes \theta_{V^*})b_V \end{aligned}$$

Exercise (b). *Prove the converse implication, i.e. show that the compatibility relation (1.6) implies that $(\theta_V)^* = \theta_{V^*}$.*

A crucial consequence of the axioms of a ribbon category is the fact that there exists a “right duality” $(*, d^-, b^-)$ as well. In turn this implies that the duality is in fact contravariant functorial and involutive. We postpone the discussion of these matters to paragraph 2.3.

1.4. *Traces and dimensions;* [1, Lemma 1.4.1]. The mentioned results on traces and dimensions, and in fact also all definitions in this paragraph are typical applications of the so called “graphical calculus” for ribbon categories. This graphical calculus is one of the applications of the Reshetikhin-Turaev functor F constructed in the next section. Therefore we must postpone [1, Lemma 1.4.1] until we understand the graphical calculus.

2. The Reshetikhin-Turaev functor F .

2.1. *Directed colored ribbon graphs.* Recall the notion of a framed tangle (or ribbon tangle). We say a ribbon tangle is directed if the framed arcs and links in the tangle are oriented. We add to this notion of framed, directed tangles an additional ingredient called *coupons*. A coupon is the image of a smooth embedding of $I \times I$ in $\mathbb{R}^2 \times (0, 1)$, remembering orientation and remembering which one of the 4 edges of its boundary rectangle is the bottom edge. Finally each coupon comes with two finite sets of distinguished points called connectors, one located on the bottom edge and the other on the top edge. We order the set of bottom connectors by the orientation (so counterclockwise) and the set of top connectors by the opposite orientation (clockwise).

A directed k, l ribbon graph G in $\mathbb{R}^2 \times I$ is a finite union of ribbon arcs, ribbon knots and coupons such that:

- (1) The arcs and knots are directed.

- (2) Each knot is disjoint from the rest of G .
- (3) Each open arc (the arc without its endpoints) is disjoint from the rest of G .
- (4) The intersection of G and $\mathbb{R}^2 \times \{0\}$ is the usual set of k tangle bottom connectors, and the intersection with $\mathbb{R}^2 \times \{1\}$ is the usual set of l tangle top connectors. Each such connector is glued to precisely one endpoint of one arc of G , such that the framing vector of the arc is $(0, -1, 0)$ at the end point (the upward normal vector, if the blackboard is the xz -plane).
- (5) Each connector of a coupon is glued to precisely one end point of one arc, in such a way that the framing vector at the connecting point is the positive unit normal vector of the coupon.
- (6) All end points of all arcs are connected in this way, either to a tangle type connector or to a coupon connector.

In particular, a directed ribbon graph without coupons is just a directed ribbon tangle.

Definition 2.3. Let \mathcal{C} be a ribbon category. A k, l \mathcal{C} -colored ribbon graph G is a directed k, l ribbon graph in which all knots and arcs of G are labelled by an object of \mathcal{C} , and all coupons C of G are labelled by a morphism of \mathcal{C} as follows: Suppose that C is of type m, n , i.e. C has m bottom and n top connectors. Then C is colored by a morphism

$$(2.1) \quad f : V_1^{\epsilon_1} \otimes \cdots \otimes V_m^{\epsilon_m} \rightarrow W_1^{\delta_1} \otimes \cdots \otimes W_n^{\delta_n}$$

in \mathcal{C} , where V_i denoted the color of the arc connecting to the i -th bottom connector of C , W_j is the color of the arc connecting to the j -th top connector of C , and the signs $\epsilon_i, \delta_j \in \{\pm 1\}$ are positive iff the strand is directed down (i.e. from top to bottom) w.r.t the connector. Here the notation $V^{\pm 1}$ is defined by $V^{+1} := V$, $V^{-1} = V^*$.

An example of a \mathcal{C} -colored coupon:

$$(2.2) \quad \begin{array}{c} \begin{array}{c} \uparrow W \quad \downarrow X \quad \uparrow Y \\ \boxed{f} \\ \uparrow S \quad \uparrow T \quad \downarrow U \quad \uparrow V \end{array} \end{array}$$

which is an admissible coloring provided that

$$(2.3) \quad f : S^* \otimes T^* \otimes U \otimes V^* \rightarrow W^* \otimes X \otimes Y^*$$

is a morphism in \mathcal{C} . We call a \mathcal{C} -colored ribbon graph which consists only of a \mathcal{C} -colored coupon (without any further knotting, linking or twisting) such as in (2.2) an *elementary \mathcal{C} -colored ribbon graph*. Observe that f can also be the color of coupons with other shapes

e.g.



or that upward oriented arcs can be reversed, at the cost of flipping the colors of these strands to their duals. For instance the following diagram is also a possible coloring:



There is an obvious notion of isotopy of \mathcal{C} -colored ribbon graphs.

The categories of colored framed tangles and graphs. We now start viewing the isotopy classes \mathcal{C} -colored ribbon graphs as morphisms of a strict monoidal category.

Definition 2.4. Let $\mathcal{T}_{\mathcal{C}}^G$ be the category whose objects are ordered finite sequences of ordered pairs (V, ϵ) consisting of an object V of \mathcal{C} and a sign $\epsilon \in \{\pm 1\}$, and whose morphisms are described as follows: Let $b := ((V_1, \epsilon_1), \dots, (V_k, \epsilon_k))$ and $t := ((W_1, \delta_1), \dots, (W_l, \delta_l))$ be objects. Then the set of morphisms $\text{Hom}_{\mathcal{T}_{\mathcal{C}}^G}(s, t)$ is the set of isotopy classes of \mathcal{C} -colored k, l ribbon graphs such that at each tangle connector the color of the connecting arc matches the object attached to the connector (i.e. the color of the strand connecting to the i -th bottom connector is V_i , and the color of the strand connecting to the j -th top connector is W_j), and the direction of the connecting strand matches the sign at the corresponding connector in the sense that downward oriented strands correspond to $+$ signs, and upward strands to $-$ signs.

The composition $S \circ T$ of two \mathcal{C} -colored ribbon graphs is given by taking the isotopy class of the colored ribbon graph obtained by putting S on top of T (and shrinking the vertical size by a factor 2).

The identity morphism of $((V_1, \epsilon_1), \dots, (V_k, \epsilon_k))$ is given by k vertical strands such that the i -th strand (connecting $(i, 0, 0)$ to $(i, 0, 1)$) has color V_i , and is oriented downwards if $\epsilon_i = +1$ and upwards if $\epsilon_i = -1$.

The following proposition is an obvious generalization of earlier results on the braid- and tangle categories.

Proposition 2.5. *This defines a category \mathcal{T}_C^G which is strict monoidal with respect to the tensor product defined on the level of objects by concatenation, and on the level of the morphisms by horizontal juxtaposition (as in the usual tangle category \mathcal{T}). The tensor unit is the empty sequence.*

2.2. The RT-representation theorem. We now present a proof of the main theorem, the Reshetikhin-Turaev representation theorem. For this proof it is of crucial importance to have a good representation by means of generators and relations (in the sense of the syllabus of week 46) of the strict monoidal category \mathcal{T}_C^G . This is done in the Appendix. You are invited to first read from the Appendix the definition of the set of RT generators (Definition 2.25), the set of RT-relations (Definition 2.27), and then read (at least) the statement of Theorem 2.28. For the remaining notations we refer to [1, Chapter 6, Section 2.1].

Theorem 2.6. ([1, Chapter 6, Theorem 2.2], [2, Chapter 1]) *Let \mathcal{C} be a strict ribbon category with braiding c , twist θ , and duality $(*, b, d)$. There exists a unique strict tensor functor $F : \mathcal{T}_C^G \rightarrow \mathcal{C}$ satisfying the following conditions:*

- (1) *For all objects V of \mathcal{C} : $F((V, +1)) = V$ and $F((V, -1)) = V^*$.*
- (2) *The F -image of an elementary \mathcal{C} -colored ribbon graph with coupon colored by f is equal to f .*
- (3) *For all objects V, W of \mathcal{C} we have*

$$F(X_{V,W}^+) = c_{V,W}, \quad F(\phi_V) = \theta_V, \quad F(\cup_V) = b_V, \quad F(\cap_V) = d_V$$

The functor F has the following properties:

$$(2.6) \quad \begin{aligned} F(X_{V,W}^-) &= c_{W,V}^{-1} & F(Y_{V,W}^+) &= c_{W,V^*}^{-1} & F(Y_{V,W}^-) &= c_{V^*,W} \\ F(Z_{V,W}^+) &= c_{W^*,V}^{-1} & F(Z_{V,W}^-) &= c_{V,W^*} & F(T_{V,W}^+) &= c_{V^*,W^*} \\ F(T_{V,W}^-) &= c_{W^*,V^*}^{-1} & F(\phi'_V) &= \theta_V^{-1} \end{aligned}$$

Proof. Using Theorem 2.28 (see the Appendix) and Theorem 4.24 of week 46 we see that a strict tensor functor from \mathcal{T}_C^G to \mathcal{C} is uniquely determined by assigning the images of the RT-generators $G_C^{G,RT}$ in such a way that images of the RT-relations $R_C^{G,RT}$ are valid in the target strict monoidal category \mathcal{C} .

We are not given a prescription for the F -image the X^- , ϕ'_V and Z -generators, but by RT-relations $R_C^{G,RT}(d)(e)(g)$ it is clear that if there exists such a strict tensor functor F then $F(X_{V,W}^-)$, $F(Z_{V,W}^\pm)$ and $F(\phi'_V)$ are determined by the images of the other RT-generators. This observation proves the uniqueness of F .

In order to establish the existence we first need to extend F to the complete set of RT-generators, and then prove that the images of the RT-relations hold with these assignments. We extend F to all the RT-generators by declaring:

$$(2.7) \quad F(X_{V,W}^-) = c_{W,V}^{-1}, \quad F(Z_{V,W}^+) = c_{W^*,V}^{-1}, \quad F(Z_{V,W}^-) = c_{V,W^*}, \quad F(\phi'_V) = \theta_V^{-1}$$

in addition to the assertions (1),(2) and(3) of the Theorem. Now we verify the validity of the RT-relations $R_C^{G,RT}(a) - (k)$ after mapping these to \mathcal{C} as described in Theorem 4.24 of week 46.

- (a) This is the Yang-Baxter equation for the braiding c of \mathcal{C} (see Chapter 2, Theorem 3.3).
- (b) This is a defining property of the duality of \mathcal{C} .
- (c) This is a defining property of the duality of \mathcal{C} .
- (d) This follows from (2.7).
- (e) This follows from (2.7).
- (f) This follows from the naturality of the braiding.
- (g) Recall that $c_{V,I} = c_{I,V} = \text{id}_V$ for all $V \in \mathcal{C}$. Hence the naturality of c implies that

$$\begin{array}{ccc} V \otimes I & \xrightarrow{\text{id}_V} & I \otimes V \\ \text{id}_V \otimes b_W \downarrow & & \downarrow b_W \otimes \text{id}_V \\ V \otimes W \otimes W^* & \xrightarrow{c_{V,W \otimes W^*}} & W \otimes W^* \otimes V \end{array}$$

or, using the braiding property of c ,

$$(b_W \otimes \text{id}_V) = (\text{id}_W \otimes c_{V,W^*}) \circ (c_{V,W} \otimes \text{id}_{W^*}) \circ (\text{id}_V \otimes b_W)$$

Using this equality we compute (following Theorem 4.24 of week 46)

$$\begin{aligned} & F(Z_{V,W}^-) \circ ((F(\cap_W) \otimes \text{id}_V \otimes \text{id}_{W^*}) \circ (\text{id}_{W^*} \otimes F(X_{V,W}^+) \otimes \text{id}_{W^*}) \circ (\text{id}_{W^*} \otimes \text{id}_V \otimes F(\cup_W))) \\ &= c_{V,W^*} \circ (d_W \otimes \text{id}_V \otimes \text{id}_{W^*}) \circ (\text{id}_{W^*} \otimes c_{V,W} \otimes \text{id}_{W^*}) \circ (\text{id}_W \otimes \text{id}_V \otimes b_W) \\ &= (d_W \otimes \text{id}_{W^*} \otimes \text{id}_V) \circ (\text{id}_{W^*} \otimes \text{id}_W \otimes c_{V,W^*}) \circ (\text{id}_{W^*} \otimes c_{V,W} \otimes \text{id}_{W^*}) \circ (\text{id}_W \otimes \text{id}_V \otimes b_W) \\ &= (d_W \otimes \text{id}_{W^*} \otimes \text{id}_V) \circ (\text{id}_{W^*} \otimes b_W \otimes \text{id}_V) \\ &= \text{id}_{W^*} \otimes \text{id}_V \end{aligned}$$

We also have the diagram

$$\begin{array}{ccc} W^* \otimes W \otimes V & \xrightarrow{c_{W^* \otimes W, V}} & V \otimes W^* \otimes W \\ d_W \otimes \text{id}_V \downarrow & & \downarrow \text{id}_V \otimes d_W \\ I \otimes V & \xrightarrow{\text{id}_V} & V \otimes I \end{array}$$

and in a similar way this leads to

$$\begin{aligned} & ((F(\cap_W) \otimes \text{id}_V \otimes \text{id}_{W^*}) \circ (\text{id}_{W^*} \otimes F(X_{V,W}^+) \otimes \text{id}_{W^*}) \circ (\text{id}_{W^*} \otimes \text{id}_V \otimes F(\cup_W))) \circ F(Z_{V,W}^-) \\ &= \text{id}_V \otimes \text{id}_{W^*} \end{aligned}$$

Together the last two identities imply that $F(Z_{V,W}^-) = c_{V,W^*}$ is the inverse of

$$(2.8) \quad (F(\cap_W) \otimes \text{id}_V \otimes \text{id}_{W^*}) \circ (\text{id}_{W^*} \otimes F(X_{V,W}^+) \otimes \text{id}_{W^*}) \circ (\text{id}_{W^*} \otimes \text{id}_V \otimes F(\cup_W))$$

Analogous computations show that $F(Z_{V,W}^+) = c_{W^*,V}^{-1}$ is the inverse of

$$(2.9) \quad (F(\cap_W) \otimes \text{id}_V \otimes \text{id}_{W^*}) \circ (\text{id}_{W^*} \otimes F(X_{V,W}^-) \otimes \text{id}_{W^*}) \circ (\text{id}_{W^*} \otimes \text{id}_V \otimes F(\cup_W))$$

(h) By the naturality and compatibility of θ we have for any $V \in \mathcal{C}$

$$\begin{aligned} b_V &= b_V \circ \text{id}_I = b_V \circ \theta_I = \theta_{V \otimes V^*} \circ b_V \\ &= c_{V^*, V} \circ c_{V, V^*} \circ (\theta_V \otimes \theta_{V^*}) \circ b_V \\ &= c_{V^*, V} \circ c_{V, V^*} \circ (\theta_V^2 \otimes \text{id}_{V^*}) \circ b_V \end{aligned}$$

or

$$(\theta_V^2 \otimes \text{id}_{V^*}) \circ b_V = c_{V, V^*}^{-1} \circ c_{V^*, V}^{-1} \circ b_V$$

Hence by the duality axioms we have

$$\theta_V^2 = (\text{id}_V \otimes d_V) \circ (c_{V, V^*}^{-1} \otimes \text{id}_V) \circ (c_{V^*, V}^{-1} \otimes \text{id}_V) \circ (b_V \otimes \text{id}_V)$$

With $F(Z_{V, V}^+) = c_{V^*, V}^{-1}$ and using that we have already shown that the F image of $R_{\mathcal{C}}^{G, RT}(g)$ is an identity in \mathcal{C} (so that $c_{V, V^*}^{-1} = F(Y_{V^*, V}^+) = (d_V \otimes \text{id}_V \otimes \text{id}_{V^*}) \circ (\text{id}_{V^*} \otimes F(X_{V, V}^+) \otimes \text{id}_{V^*}) \circ (\text{id}_{V^*} \otimes \text{id}_V \otimes b_V)$) we get

$$\begin{aligned} F(\theta_V^2) &= \theta_V^2 \\ &= (\text{id}_V \otimes d_V) \circ (d_V \otimes \text{id}_V \otimes \text{id}_{V^*} \otimes \text{id}_V) \circ (\text{id}_{V^*} \otimes F(X_{V, V}^+) \otimes \text{id}_{V^*} \otimes \text{id}_V) \circ \\ &\quad (\text{id}_{V^*} \otimes \text{id}_V \otimes b_V \otimes \text{id}_V) \circ (F(Z_{V, V}^+) \otimes \text{id}_V) \circ (b_V \otimes \text{id}_V) \\ &= (d_V \otimes \text{id}_V) \circ (\text{id}_{V^*} \otimes \text{id}_V \otimes \text{id}_V \otimes d_V) \circ (\text{id}_{V^*} \otimes F(X_{V, V}^+) \otimes \text{id}_{V^*} \otimes \text{id}_V) \circ \\ &\quad (\text{id}_{V^*} \otimes \text{id}_V \otimes b_V \otimes \text{id}_V) \circ (F(Z_{V, V}^+) \otimes \text{id}_V) \circ (b_V \otimes \text{id}_V) \\ &= (d_V \otimes \text{id}_V) \circ (\text{id}_{V^*} \otimes F(X_{V, V}^+)) \circ (\text{id}_{V^*} \otimes \text{id}_V \otimes \text{id}_V \otimes d_V) \circ \\ &\quad (\text{id}_{V^*} \otimes \text{id}_V \otimes b_V \otimes \text{id}_V) \circ (F(Z_{V, V}^+) \otimes \text{id}_V) \circ (b_V \otimes \text{id}_V) \\ &= (d_V \otimes \text{id}_V) \circ (\text{id}_{V^*} \otimes F(X_{V, V}^+)) \circ (F(Z_{V, V}^+) \otimes \text{id}_V) \circ (b_V \otimes \text{id}_V) \\ &= (F(\cap_V) \otimes \text{id}_V) \circ (\text{id}_{V^*} \otimes F(X_{V, V}^+)) \circ (F(Z_{V, V}^+) \otimes \text{id}_V) \circ (F(\cup_V) \otimes \text{id}_V) \end{aligned}$$

which is what we needed to show.

(i) We have reached the stage that we have checked existence and uniqueness of the functor F on the full subcategory $\mathcal{T}_{\mathcal{C}}$ of $\mathcal{T}_{\mathcal{C}}^G$. Let us now check that the F -images of the Y and T crossings are as asserted.

The asserted F -values of $Y_{V, W}^{\pm}$ follows from the remark that $Y_{V, W}^{\pm} = (Z_{W, V}^{\mp})^{-1}$ in $\mathcal{T}_{\mathcal{C}}$ and applying F .

For the asserted F -values of $T_{V, W}^{\pm}$ it is enough to verify the F -value of $T_{V, W}^+$ (since $T_{W, V}^-$ is its inverse). This value can be checked using the the relation of Figure (18) implying that in $\mathcal{T}_{\mathcal{C}}$:

$$(2.10) \quad T_{V, W}^+ = ((d_W \otimes \text{id}_{V^*} \otimes \text{id}_{W^*}) \circ (\text{id}_{W^*} \otimes Y_{V, W}^- \otimes \text{id}_{W^*}) \circ (\text{id}_{W^*} \otimes \text{id}_{V^*} \otimes b_W))^{-1}$$

Now repeat the proof for $F(Z_{V, W}^-)$ (which is part of $R_{\mathcal{C}}^{G, RT}$) but with V replaced by V^* , using the already established value $F(Y_{V, W}^-) = c_{V^*, W}$. This yields the result.

Now we go back to the task at hand, proving the crossing relation (i) for coupons. If all the strands of the coupon are oriented downwards then this is true by the naturality of the braiding, since the F -image of the crossings of the top strand

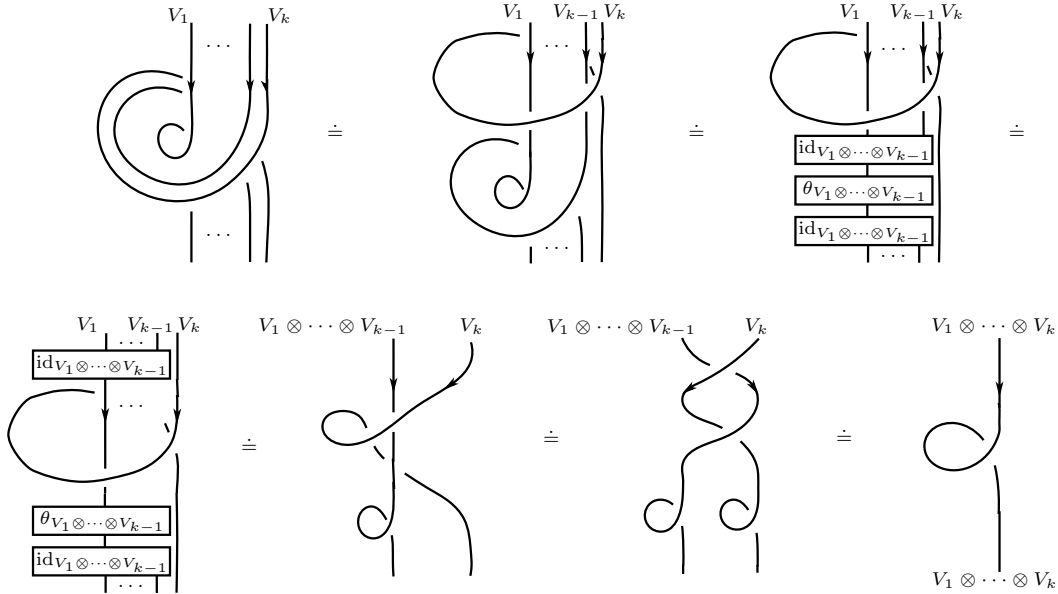

FIGURE 1. The F -image of the right positive downward twist.

with the strands connected to the top of the coupon is (by the braiding property of c) equal to $c_{V,t(f)}$, and the F -image of the crossing of the top strand with the strands connected to the bottom of the coupon is equal to $c_{V,s(f)}$ (V the color of the top strand). We reduce the general case to this case. If necessary we change the orientation of a strand and replace its color to the dual color. This is allowed (the coloring of the coupon stays admissible) and the F image of the coupon does not change. Also the F -images of the crossings do not change, since $F(X_{V,W^*}) = F(Z_{V,W}^-) = c_{V,W^*}$. Hence without changing the F -images of both sides we reduce to the case with all strands oriented downwards.

- (j) This is similar to the proof of (i).
- (k) If all strands are oriented downwards this follows from the naturality of the twist θ , since the F -image of the full right hand twist of k strands (see Figure 15) with downward orientation and color V_1, \dots, V_k is equal to $\theta_{V_1 \otimes \dots \otimes V_k}$, (and hence the F -image of the full left hand twist is $\theta_{V_1 \otimes \dots \otimes V_k}^{-1}$). Indeed, this is true for $k = 1$ and by using induction on k and the definition of a the twist we easily prove this in general (see Figure 1).

Now we reduce to this case with the same observations as we used for (i) and (j). □

2.3. *Graphical Calculus for ribbon categories.* The existence of the Reshetikhin-Turaev functor F represents a deep insight in the general structure of ribbon categories and their relation to the topology of ribbon tangles.

The so called graphical calculus in a ribbon category \mathcal{C} exploits F in order to compute in \mathcal{C} . We represent a morphism f in \mathcal{C} as the F -image of a \mathcal{C} -colored ribbon graph T say, thus $f = F(T)$. Furthermore T can be represented by a generic \mathcal{C} -colored ribbon graph diagram D , and we may and will assume that the coupons of D are rectangles with horizontal and vertical edges, with their faces up and with their bottom edges down. We may then manipulate T (or better, D) in such a way that its F -value $F(T)$ does not change. The basic invariances of F are the following operations on D :

- (i) Change D in accordance with an ambient isotopy of T (in $\mathbb{R}^2 \times I$).
- (ii) Use a coupon as a placeholder for a \mathcal{C} -colored ribbon sub-graph, by which we mean the following. Let $R = (a, b) \times (c, d) \subset \mathbb{R} \times (0, 1)$ be a rectangle such that $\partial(R) \cap D$ consists of a finite set of generic points of strands of D (local extrema, crossings, or points of coupons of D are not allowed) which are all located either in $\{c\} \times (a, b)$ (the bottom edge of R) or in $\{d\} \times (a, b)$ (the top edge of R). Let $E = R \cap D$. Then E can itself be considered as a generic \mathcal{C} -colored ribbon graph diagram (by stretching R in the vertical direction and fitting it in the usual tangle diagram strip $\mathbb{R} \times [0, 1]$), representing a \mathcal{C} -colored ribbon graph T_E (determined by E up to isotopy). Then F is invariant for the following operation: we replace the subdiagram E of D by the rectangle R , now viewed as a coupon which is colored by the morphism $f = F(T_E)$ (or conversely, replace a coupon with color f by a \mathcal{C} -colored ribbon graph subdiagram E drawn inside the coupon such that the corresponding \mathcal{C} -colored ribbon graph T_E satisfies $f = F(T_E)$).
- (iii) Absorb or create a coupon colored by an identity morphism at the bottom or top of D , and change the number of strands of top or bottom tangle connectors of D accordingly.

Indeed, (i) follows because F is an isotopy invariant, and (ii), (iii) follow because F is a strict tensor functor.

If T, T' satisfy $F(T) = F(T')$ we denote this by $T \doteq T'$. The equivalence relation \doteq is referred to as F -equivalence. Manipulating \mathcal{C} -colored ribbon graphs using F -equivalences is called “graphical calculus”. For example graphical calculus was used in Figure 1.

Exercise (c). *Explain the F -equivalences of Figure 1 in terms of the basic invariances of F as mentioned above, together with the induction hypothesis and the definition of the twist. Explain that these steps do not depend on the assumption that F is invariant for $R_{\mathcal{C}}^{G, RT}(k)$ (so that the argument is allowed to prove the invariance of F for $R_{\mathcal{C}}^{G, RT}(k)$).*

Let us now show some typical applications of the graphical calculus. First of all, let us give a graphical proof of Proposition 1.1, namely $(fg)^* = g^*f^*$ (where $f : V \rightarrow W$ and $g : U \rightarrow V$):

Definition 2.7. *We define the right duality $(*, b^-, d^-)$ in \mathcal{C} by $b_V^- := F(\cup_V^-) : I \rightarrow V^* \otimes V$ and $d_V^- := F(\cap_V^-) : V \otimes V^* \rightarrow I$ (see Figures 20 and 19).*

By graphical calculus it is obvious that:

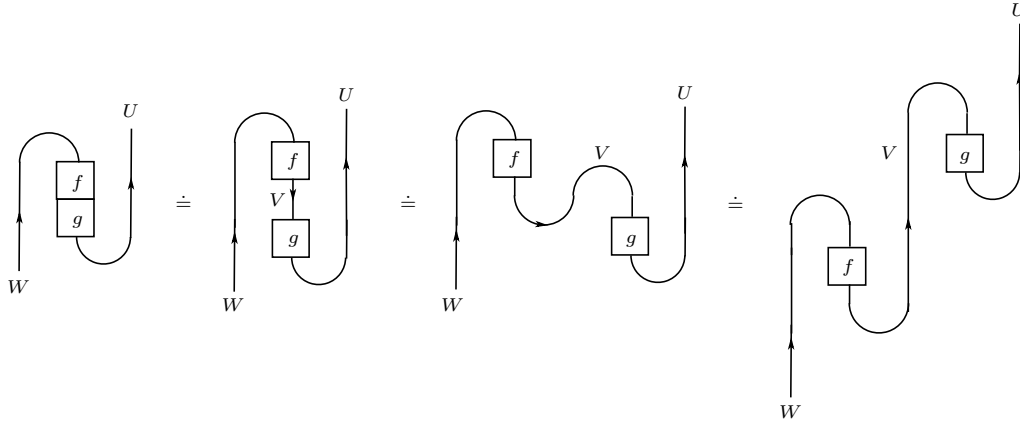

FIGURE 2. Proof of Proposition 1.1

Proposition 2.8. *For any object $V \in \mathcal{C}$ we have:*

$$\begin{aligned} \text{id}_V &= (d_V^- \otimes \text{id}_V) \circ (\text{id}_V \otimes b_V^-) \\ \text{id}_{V^*} &= (\text{id}_{V^*} \otimes d_V^-) \circ (b_V^- \otimes \text{id}_{V^*}) \end{aligned}$$

There are easy relations between transpose morphisms and the left and right dualities of \mathcal{C} :

Proposition 2.9. *For any morphism $f : V \rightarrow W$ we have*

$$\begin{aligned} (f \otimes \text{id}_{V^*}) \circ b_V &= (\text{id}_W \otimes f^*) \circ b_W \\ (\text{id}_{V^*} \otimes f) \circ b_V^- &= (f^* \otimes \text{id}_W) \circ b_W^- \\ d_W \circ (\text{id}_{W^*} \otimes f) &= d_V \circ (f^* \otimes \text{id}_V) \\ d_W^- \circ (f \otimes \text{id}_{W^*}) &= d_V^- \circ (\text{id}_V \otimes f^*) \end{aligned}$$

Exercise (d). *Prove Proposition 2.9 using graphical calculus.*

Using Proposition 2.9 it is easy to prove that the right duality defines the same notion transpose morphisms as was defined before with the left duality:

Corollary 2.10.

$$(2.11) \quad f^* = (\text{id}_{V^*} \otimes d_W^-) \circ (\text{id}_{V^*} \otimes f \otimes \text{id}_{W^*}) \circ (b_V^- \otimes \text{id}_{W^*})$$

Proposition 2.11. *There exists a natural isomorphism $\alpha : \text{id}_{\mathcal{C}} \rightarrow * \circ *$.*

Proof. Define $\alpha : V \rightarrow V^{**}$ and $\beta_V : V^{**} \rightarrow V$ by Figure 3. It is easy to see by graphical calculus that α_V and β_V are inverse isomorphisms. To show the naturality we need to show that for morphisms $f : V \rightarrow W$ we have $f^{**}\alpha_V = \alpha_W f$. This we prove by Proposition 2.9 and graphical calculus (see Figure 4). \square

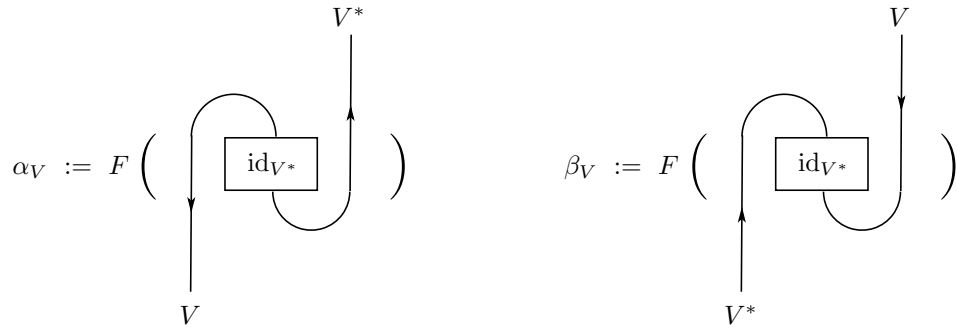

FIGURE 3. The natural isomorphisms between V and V^{**} .

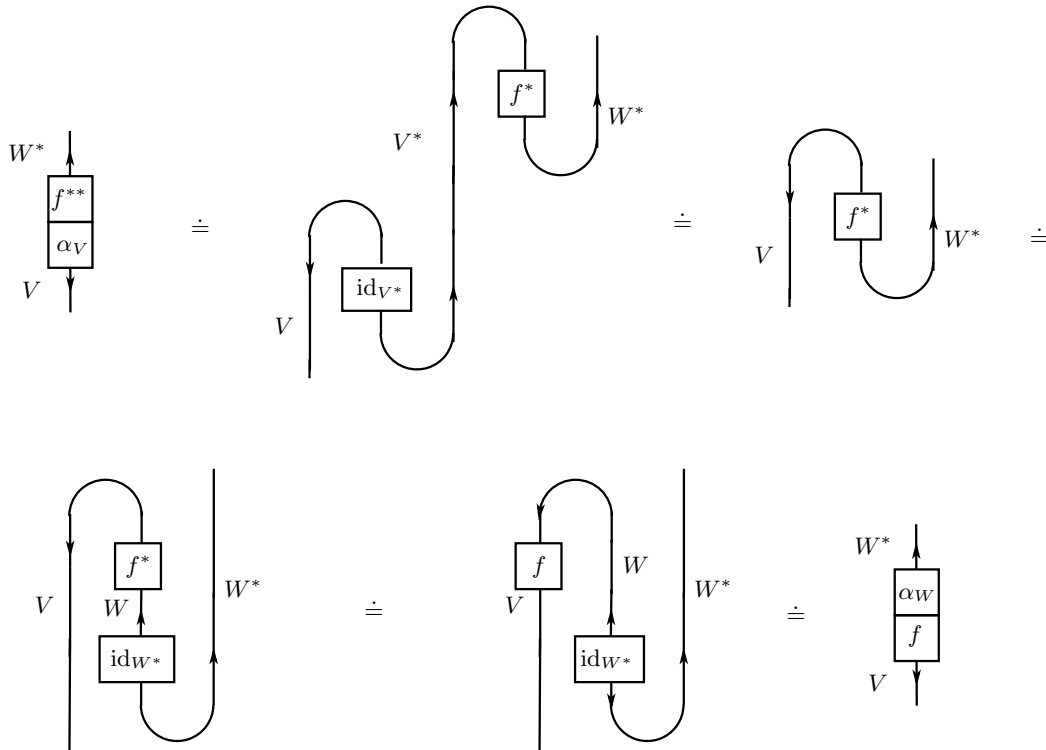

FIGURE 4. The naturality of α

Remark 2.12. Using Proposition 2.11 we will from now on identify V and V^{**} and f and f^{**} . In particular we may change in the graphical calculus the orientation of any strand (up or down) and at the same time dualize its color, see Figure 5.

Recall the inverse isomorphisms $\lambda_{U,V}$ and $\mu_{U,V}$. They can be represented by the graphs of Figure 6



FIGURE 5. Identification of f and f^{**} .

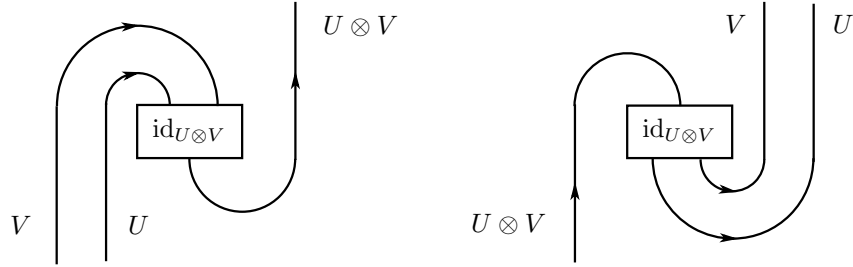

FIGURE 6. Graphs representing $\lambda_{U,V}$ and $\mu_{U,V}$ respectively

Remark 2.13. *By graphical calculus one can prove easily that the family of isomorphisms $\lambda_{U,V}, \mu_{U,V}$ of Proposition 1.2 are natural (finishing the proof of Proposition 1.2).*

This allows us to identify $(U \otimes V)^$ and $V^* \otimes U^*$.*

Proposition 2.14. *Observe that Exercise (a) implies that with this identification,*

$$b_{U \otimes V} = (\text{id}_U \otimes b_V \otimes \text{id}_{U^*})b_U$$

$$d_{U \otimes V} = d_V(\text{id}_{V^*} \otimes d_U \otimes \text{id}_V)$$

(see Figure 7). In fact we have similar relations for the right dualities and the tensor product, as is proved for the cap in Figure 8, and as is displayed for the cup in Figure 9. (The proof of Figure 8 uses the identity Figure 1.)

The quantum trace in \mathcal{C} ; quantum dimension. Finally we are in the position to prove [1, Chapter 6, Lemma 1.4.1](!)

Recall the following basic property of strict monoidal categories:

Proposition 2.15. *Let \mathcal{C} be a strict monoidal category. The monoid of endomorphisms $K := \text{End}_{\mathcal{C}}(I)$ of the tensor unit I is commutative. Moreover if $f, g \in \text{End}_{\mathcal{C}}(I)$ then we have $f \circ g = f \otimes g$.*

Proof. Let $f, g : I \rightarrow I$. Recall that $I = I \otimes I$ and $f = f \otimes \text{id}_I = \text{id}_I \otimes f$. Hence $fg = (f \otimes \text{id}_I)(\text{id}_I \otimes g) = (\text{id}_I \otimes g)(f \otimes \text{id}_I) = gf$. We also see that $fg = f \otimes g$. \square

Exercise (e). *Give the graphical representation of Proposition 2.15*

The following fact is also useful:

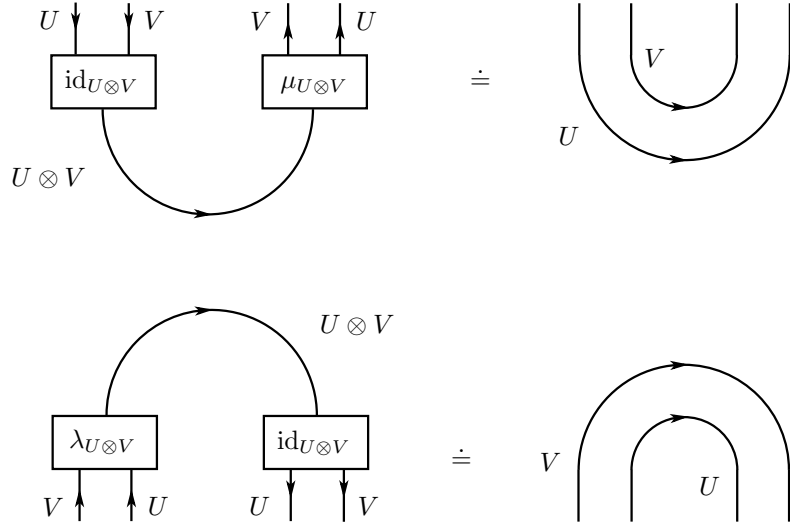

FIGURE 7. Left duality and tensor products

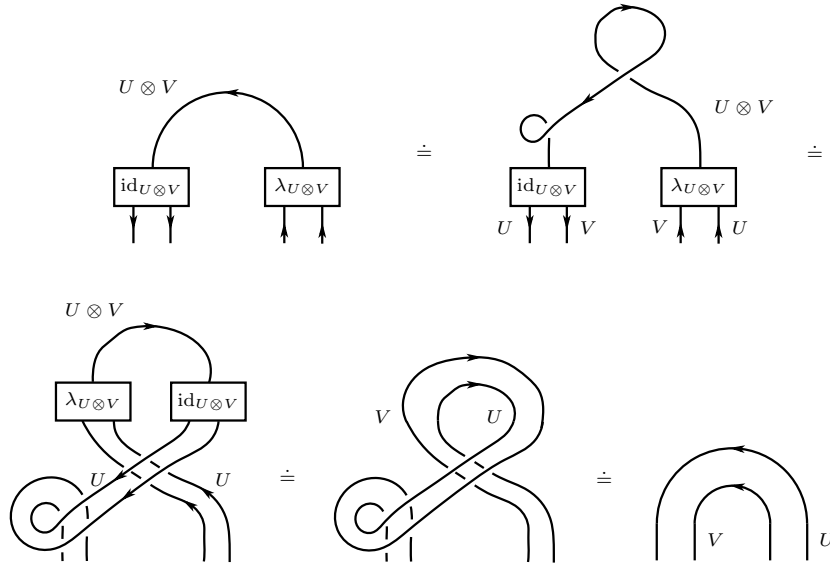
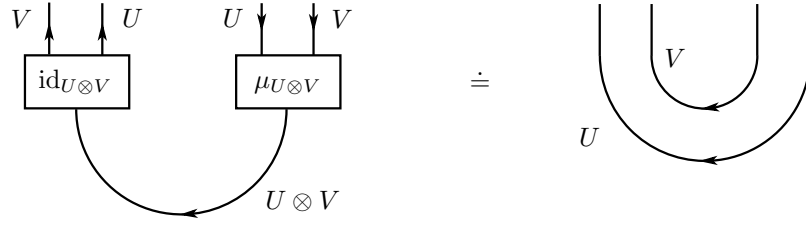

FIGURE 8. The cap \cap^- of a tensor product

Proposition 2.16. *The morphisms $b_I : I \rightarrow I \otimes I^* = I^*$ and $d_I : I^* \otimes I = I^* \rightarrow I$ are inverse isomorphisms. For all $k \in K := \text{End}_C(I)$ we have $k^*b_I = b_Ik$.*

Proof. We first show that $b_I : I \rightarrow I \otimes I^* = I^*$ and $d_I : I^* \otimes I = I^* \rightarrow I$ are inverse isomorphisms of each other. Duality gives $\text{id}_I = (\text{id}_I \otimes d_I)(b_I \otimes \text{id}_I) = d_I b_I$. Now remark

 FIGURE 9. The cup U^- of a tensor product

that I is isomorphic to I^* : we have $I \simeq I^{**}$, and thus

$$(2.12) \quad I^* = I^* \otimes I \simeq I^* \otimes I^{**} \simeq (I^* \otimes I)^* \simeq I^{**} \simeq I$$

Let $g : I \rightarrow I^*$ be any isomorphism. Then $g^{-1}b_I, d_I g \in K$. By the commutativity of K we have:

$$(2.13) \quad g^{-1}(b_I d_I)g = (g^{-1}b_I)(d_I g) = (d_I g)(g^{-1}b_I) = d_I b_I = \text{id}_I$$

or $b_I d_I = \text{id}_{I^*}$. This proves the first assertion. Finally we compute

$$(2.14) \quad k^* b_I = (\text{id}_I \otimes k^*)b_I = (k \otimes \text{id}_{I^*})b_I = (k \otimes \text{id}_I \otimes \text{id}_{I^*})b_I = b_I k$$

□

Definition 2.17. If $f : V \rightarrow V$ is a morphism in \mathcal{C} we define its quantum trace $\text{tr}_{\mathcal{C}}(f) \in \text{End}_{\mathcal{C}}(I)$ as follows:

$$(2.15) \quad \text{tr}_{\mathcal{C}}(f) := d_V \circ (\text{id}_{V^*} \otimes f \theta_V^{-1}) \circ c_{V^*, V}^{-1} \circ b_V$$

If $V \in \mathcal{C}$ then its quantum dimension is defined as $\dim_{\mathcal{C}}(V) := \text{tr}_{\mathcal{C}}(\text{id}_V)$.

Graphical calculus yields some useful alternative expressions for the trace, see Figure 10. The following proposition shows that the quantum trace indeed behaves like a trace.

Proposition 2.18. We have

- (1) If $f : V \rightarrow W$ and $g : W \rightarrow V$ then $\text{tr}_{\mathcal{C}}(fg) = \text{tr}_{\mathcal{C}}(gf)$.
- (2) If $f : V \rightarrow V$ and $g : W \rightarrow W$ then $\text{tr}_{\mathcal{C}}(f \otimes g) = \text{tr}_{\mathcal{C}}(f)\text{tr}_{\mathcal{C}}(g)$.
- (3) If $f : I \rightarrow I$ then $\text{tr}_{\mathcal{C}}(f) = f$.

Proof. (1) Graphical calculus.

(2) Graphical calculus; see Figure 11.

(3) Recall that $c_{I, V} = \text{id}_V$ (for any object V) and $\theta_I = \text{id}_I$. Hence (using Figure 10, Proposition 2.9, and Proposition 2.16):

$$\begin{aligned} \text{tr}_{\mathcal{C}}(f) &= d_I c_{I, I^*} \circ (f \theta_I \otimes \text{id}_{I^*}) \circ b_I \\ &= d_I (f \otimes \text{id}_{I^*})b_I = d_I (\text{id}_I \otimes f^*)b_I = d_I f^* b_I = d_I b_I f = f \end{aligned}$$

□

Corollary 2.19. Let \mathcal{C} be a ribbon category, as usual. The quantum dimension has the following properties:

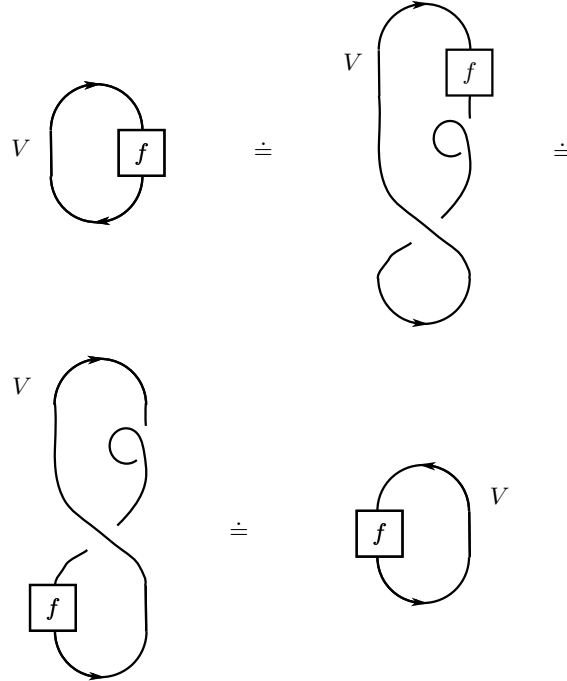
FIGURE 10. The quantum trace of $f : V \rightarrow V$

- (1) *Isomorphic objects have the same dimension.*
- (2) *Dual objects have the same dimension.*
- (3) *We have $\dim_{\mathcal{C}}(V \otimes W) = \dim_{\mathcal{C}}(V)\dim_{\mathcal{C}}(W)$.*
- (4) *We have $\dim_{\mathcal{C}}(I) = \text{id}_I := 1 \in K$.*

Remark 2.20. *We remark that in the graphical calculation of Figure 11 we have used carefully the preceding remarks on the canonical identification of $(V \otimes W)^*$ with $W^* \otimes V^*$ and the behavior of cup and cap under tensor product. In this way we avoided pulling a “zipper coupon” labelled $\text{id}_{V \otimes W}$ past a cup or cap (after which action the coupon would be upside down). However, the RT-theorem tells us that this is actually no problem (!) and moreover we have even seen in detail in the above example how this works fine and that one can avoid at all times putting coupons upside down. So we may now forget about it and freely use the invariance of F for the “unzipping” of a strand whose color is the tensor product $V \otimes W$ in two parallel strands whose colors are V and W . We will also usually not mention the identifications $\lambda_{V,W}$ and $\mu_{V,W}$ explicitly.*

Exercise (f). *Prove Proposition 2.18(1)*

Exercise (g). *Prove Corollary 2.19*

Exercise (h). *Let V, W be objects of \mathcal{C} . Show that the trace $S_{V,W} := \text{tr}_{\mathcal{C}}(c_{W,V} \circ c_{V,W})$ satisfies $S_{V,W} = S_{W,V}$. Show that $S_{V,W}$ is the F -image of a positive Hopf link whose two components are colored by V and W .*

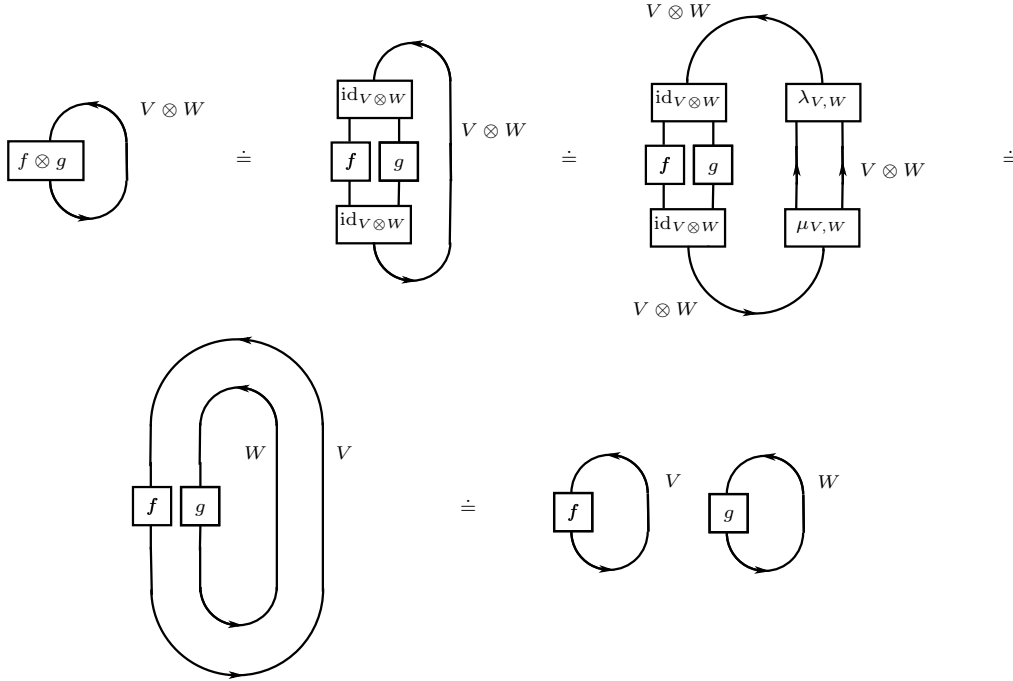

FIGURE 11. The trace of $f \otimes g$

The RT representation Theorem and ribbon link invariants. So far we have mainly used the RT-representation Theorem 2.6 as a tool to facilitate the computations in a ribbon category by topology (graphical calculus). This is extremely useful, but the deepest application of the theorem goes in the opposite direction: The RT-Theorem 2.6 produces a \mathcal{C} -colored ribbon link invariant whenever we are given a ribbon category \mathcal{C} .

It has been shown (Drinfeld, Lusztig) that the simple complex Lie algebras are a source of ribbon categories. In fact one can show that the universal quantum enveloping algebra $U_q(\mathfrak{g})$ of \mathfrak{g} is close to being a so called ribbon algebra. This implies that the category of representations of $U_q(\mathfrak{g})$ -modules has the structure of a ribbon category (with $K = \mathbb{Z}[q^{1/2}, q^{-1/2}]$). In this course we will prove this for $\mathfrak{g} = \mathfrak{sl}_n$.

In particular every choice of a finite dimensional representation V of $U_q(\mathfrak{g})$ gives rise to a directed ribbon link invariant $P_V(L)$ defined by $P_V(L) := F(L_V) \in \mathbb{Z}[q^{1/2}, q^{-1/2}]$, where L_V denotes the link L with all its strands colored by the object V .

For the case of $\mathfrak{g} = \mathfrak{sl}_2$, and V its 2-dimensional representation one reconstructs in this way the Kauffman bracket polynomial (as we will see next week), leading to the Jones polynomial. For the higher dimensional representations of \mathfrak{sl}_2 one is lead to the so-called colored Jones polynomials. The defining n -dimensional representation V of \mathfrak{sl}_n will give us the Homfly polynomial discussed in the beginning of this course.

Exercise (i). Let G be an abelian group, and K a commutative ring with unit. Let K^\times be the multiplicative group of invertible elements in K . Let $c : G \times G \rightarrow K^\times$ be a bilinear

pairing, i.e. $c(g, hh') = c(g, h)c(g, h')$ and $c(gg', h) = c(g, h)c(g', h)$ for all $g, g', h, h' \in G$. Let $\phi : G \rightarrow K^\times$ be a character of G (i.e. $\phi(gh) = \phi(g)\phi(h)$ for all $g, h \in G$) such that $\phi(g^2) = 1$ for all $g \in G$.

Let \mathcal{V} be the strict monoidal category whose objects are given by the elements of G , with tensor product of $g, h \in G$ defined by $g \otimes h := gh \in G$, and with $\text{Hom}_{\mathcal{V}}(g, h) = K$ if $g = h$ and $\text{Hom}_{\mathcal{V}}(g, h) = \{0\} \subset K$ else. Let the composition and tensor product of morphisms in \mathcal{V} be defined by the product of the corresponding elements of the ring K . This defines a strict monoidal structure on \mathcal{V} with the identity e of G as the tensor unit object (you may use these facts without proof).

- (1) Define $c_{g,h} := c(g, h) \in K$ and $\theta_g := \phi(g)c(g, g) \in K$ for all $g, h \in G$ and prove that this gives \mathcal{V} the structure of a braided monoidal category with braiding c and twist θ .
- (2) Define $g^* := g^{-1}$, $b_g = 1$ and $d_g = 1$ for all $g \in G$, and prove that the triple $(*, b, d)$ defines a compatible duality on \mathcal{V} . We denote the resulting strict ribbon category by $\mathcal{V}(G, K, c, \phi)$.
- (3) Give an example of such a ribbon category $\mathcal{V}(G, K, c, \phi)$ for which the braiding is not symmetric.
- (4) Let $F = F_{\mathcal{V}(G, K, c, \phi)}$ be the Reshetikhin-Turaev functor associated to $\mathcal{V}(G, K, c, \phi)$. Prove that $F(\bigcup_g) = F(\bigcap_g) = \phi(g)$ for all $g \in G$.
- (5) Compute the dimension $\dim(g)$ for any object $g \in G$.
- (6) Let $L = L_1 \cup L_2 \cup \dots \cup L_m$ an m -component framed link. Give the definition of the linking number $l_{i,j} = \text{Lk}(L_i, L_j)$ of the components L_i and L_j and of the framing number (or linking number) $l_i = \text{Lk}(L_i)$ of one component L_i .
- (7) Suppose that we color the component L_i with color $g_i \in G$. Prove that with this coloring:

$$F(L) = \prod_{1 \leq j < k \leq m} (c(g_j, g_k)c(g_k, g_j))^{l_{j,k}} \prod_{j=1}^m c(g_j, g_j)^{l_j} \phi(g_j)^{l_j+1}$$

Appendix: Proof of the Reshetikhin-Turaev presentation.

The category $\mathcal{T}_C^{G, RM}$. Recall the definition of a presentation of a strict monoidal category as discussed in the syllabus of week 46. In particular recall the derivation of a presentation of the tangle category \mathcal{T} on the basis of Reidemeister's theorem. We will now consider the analogous presentation for \mathcal{T}_C^G using an obvious extension of Reidemeister's theorem (by including the colorings and coupons). This will give rise to an algebraic presentation $\mathcal{T}_C^{G, RM}$ of \mathcal{T}_C^G .

Definition 2.21. Consider the strict monoidal category $\mathcal{T}_C^{G, RM}$ generated by the set $G_C^{G, RM}$ of morphisms of \mathcal{T}_C^G consisting of the crossings $\{X_{V,W}^\pm, Y_{V,W}^\pm, Z_{V,W}^\pm, T_{V,W}^\pm\}$ as defined in [1, Chapter 6, Figure 2.1] (where V, W run over all possible objects of \mathcal{C}), the cups $\{\cup_V, \cup_{\bar{V}}\}$ and caps $\{\cap_V, \cap_{\bar{V}}\}$ as defined in [1, Chapter 6, Figure 2.2, bottom row], and finally the elementary \mathcal{C} -colored ribbon graphs. Let $R_C^{G, RM}$ be the set of relations given in week 46,

Theorem 4.22 (1)-(6) (including the diagram isotopies (1)-(3) and the ribbon Reidemeister moves of types $\Omega_0, \Omega_2, \Omega_3$) with all possible coloring and orientations of the strands involved, complemented by the relations displayed in figures 12 and 13 (with all possible orientations of the strands connecting to the coupon, and all admissible colorings), and finally the relation of figure 14 (again, for all colorings and all orientations of the strands).

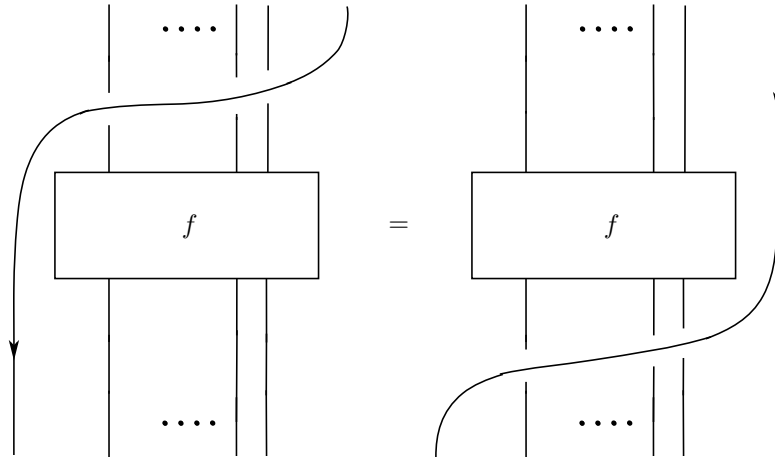

FIGURE 12. Crossings over a coupon

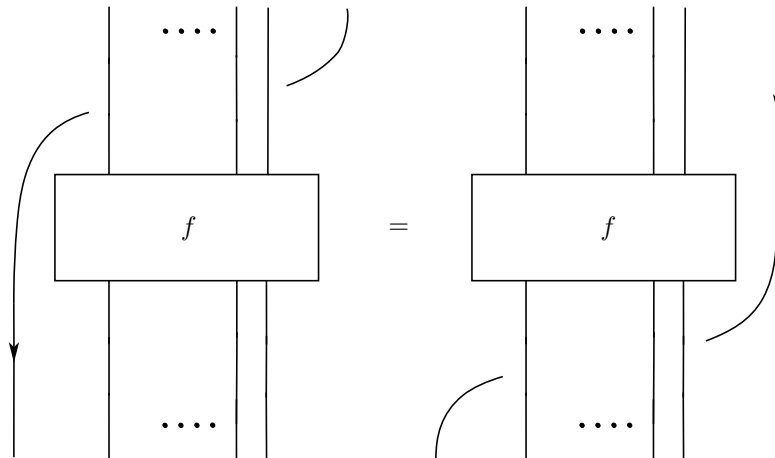

FIGURE 13. Crossing under a coupon

Remark 2.22. *We emphasize that in figure 14 the ovals marked “r-twist” and “l-twist” are NOT coupons(!), but refer to the full right hand twist and full left hand twist respectively of all strands together, which can be expressed in terms of our generators by means of a picture like Figure 15*

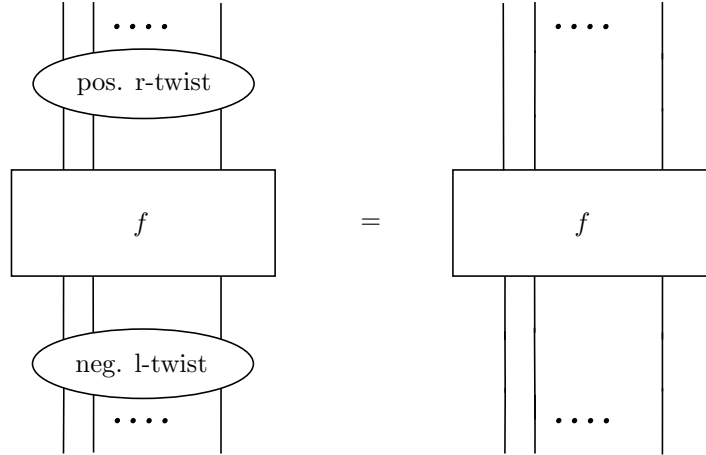

FIGURE 14. Twisting a coupon

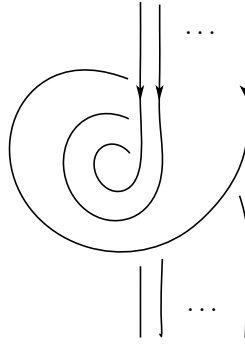

FIGURE 15. The right hand positive twist.

Remark 2.23. *The crossing relations of an upward directed strand over or under a coupon are not included because these relations are consequences of the other relations (namely (1)-(3) with the crossing relations for coupons and downward strands).*

As an extended version of Reidemeister's theorem (with colors, directions and coupons) we have:

Theorem 2.24. *The pair $(G_C^{G, RM}, R_C^{G, RM})$ is a presentation of \mathcal{T}_C^G . In other words, the canonical strict tensor functor $F(G_C^{G, RM}) \rightarrow \mathcal{T}_C^G$ from the free monoidal category $F(G_C^{G, RM})$ generated by $G_C^{G, RM}$ factors through $\mathcal{T}_C^{G, RM}$ and then gives rise an isomorphism of categories $\rho: \mathcal{T}_C^{G, RM} \rightarrow \mathcal{T}_C^G$.*

Proof. We first represent \mathcal{C} -colored, directed k, l ribbon graph by a \mathcal{C} colored, directed k, l graph diagram by a generic projection onto the (x, z) -plane. For this we first move the coupons of the graph in a position such that their projections to the z -axes are disjoint (distinct heights) and their position is parallel to the (x, z) plane, with bottom edge down

and face side up. This can obviously be done. We “freeze” the coupons in these positions and put all strands (arcs and knot components) in a position so that their projection to the (x, y) plane is generic. Finally we put in little curls in each arc or knot component so that we can put the framing vector everywhere in blackboard position. The projection graphs diagram can be moved still by small diagram isotopies so as to get a generic diagram, with its singular points and coupons all at distinct heights and only nondegenerate extrema as the stationary points of the height function on its arcs. From here on the proof is completely analogous to the proof of Theorem 4.22 of week 46, and we therefore omit this. \square

2.4. *The category $\mathcal{T}_C^{G,RT}$.* The presentation of \mathcal{T}_C^G given by Theorem 2.24 is easy to prove but has as a drawback that it uses much more generators than necessary, making it inefficient to apply directly. The most substantial part of the proof of the Reshetikhin-Turaev representation theorem consists of improving the presentation.

Definition 2.25. *The set $G_C^{G,RT}$ of morphisms of \mathcal{T}_C^G consist of the union of the sets $\{X_{V,W}^\pm, Z_{V,W}^\pm, \cup_V, \cap_V, \phi_V, \phi'_V\}$, where V and W run over the set of objects of \mathcal{C} and where ϕ_V and ϕ'_V are define by figure 16, and the collection of elementary colored ribbon graphs*

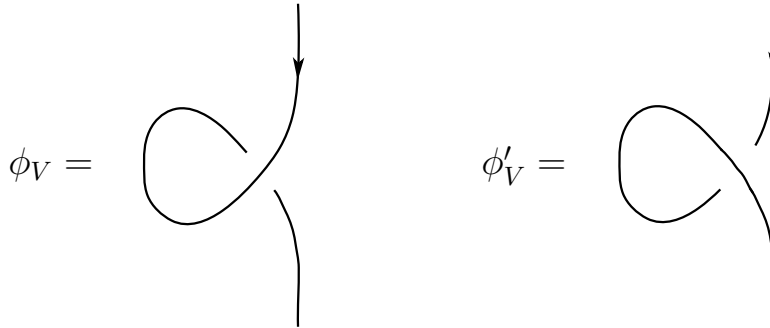

FIGURE 16. The positive curl and the negative curl

(as exemplified by (2.2)).

Proposition 2.26. *The set $G_C^{G,RT}$ is a set of generators of \mathcal{T}_C^G .*

Proof. In view of Theorem 2.24 it suffices to express the generators of the set $G_C^{G,RM}$ in terms of $G_C^{G,RT}$ modulo $R_C^{G,RM}$ -equivalences. For the elements of $G_C^{G,RM} \setminus G_C^{G,RT}$ this is shown by the figures 17, 18 in combination with the analogous formulas for $Y_{V,W}^-$ and $T_{V,W}^-$, and the formulas of figures 19 and 20. \square

Definition 2.27. *We define a set of relations $R_C^{G,RT}$ as the union of the following relations (as usual, with all possible \mathcal{C} colorings) between RT generators. Besides the generators $G_C^{G,RT}$ we use the notation \downarrow_V (\uparrow_V) for a single straight arc oriented downwards (upwards), colored with V (which are identities in \mathcal{T}_C^G).*

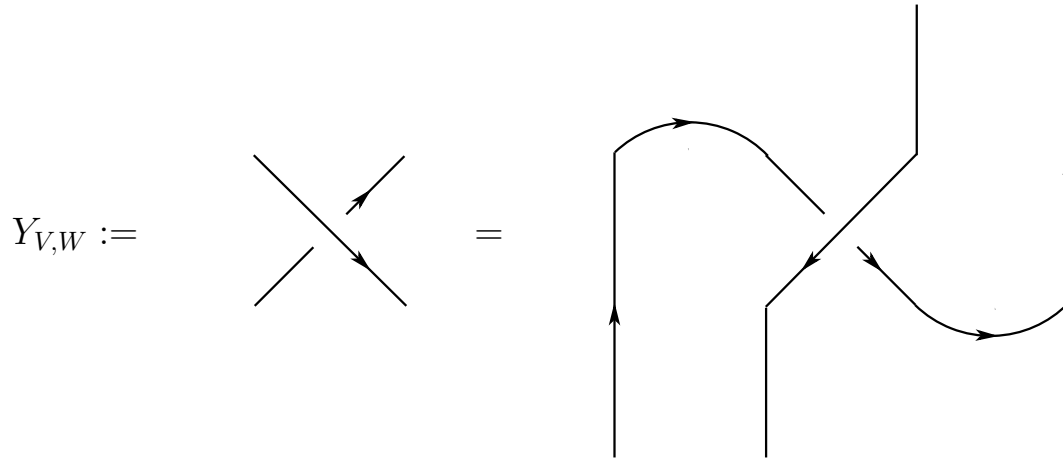

FIGURE 17. Expressing Y's in RT-generators

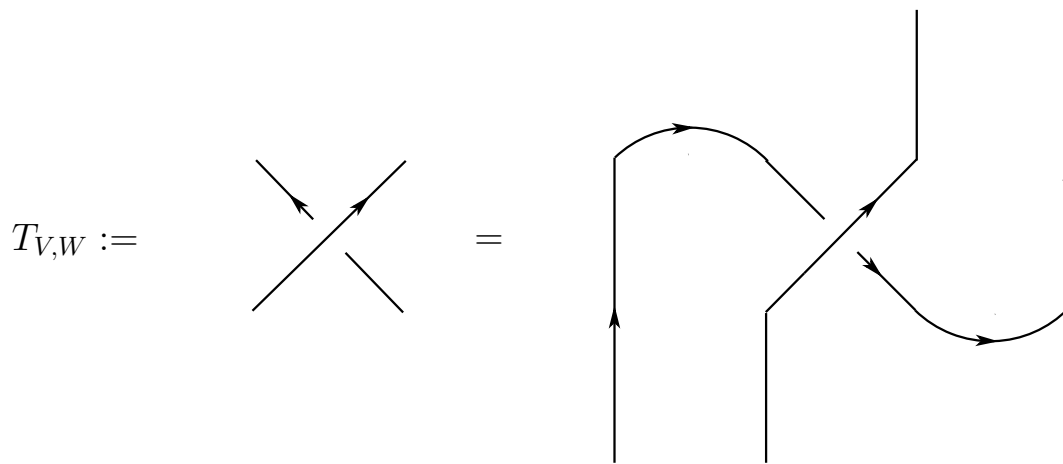

FIGURE 18. Expressing T's in Y's and RT generators.

- (a) Reidemeister 3 (or Ω_3) for X^+ -crossings (all crossings positive, all strands downwards).
- (b) Annihilation or creation of a cup-cap pair, oriented downwards, i.e.

$$\downarrow_V = (\downarrow_V \otimes \cap_V) \circ (\cup_V \otimes \downarrow_V)$$

- (c) Annihilation or creation of a cap-cup pair, oriented upwards, i.e.

$$\uparrow_V = (\cap_V \otimes \uparrow_V) \circ (\uparrow_V \otimes \cup_V)$$

- (d) Reidemeister 2 (or Ω_2) with both strands oriented downwards, i.e. $X_{V,W}^- = (X_{W,V}^+)^{-1}$.
- (e) $\phi'_V = \phi_V^{-1}$.

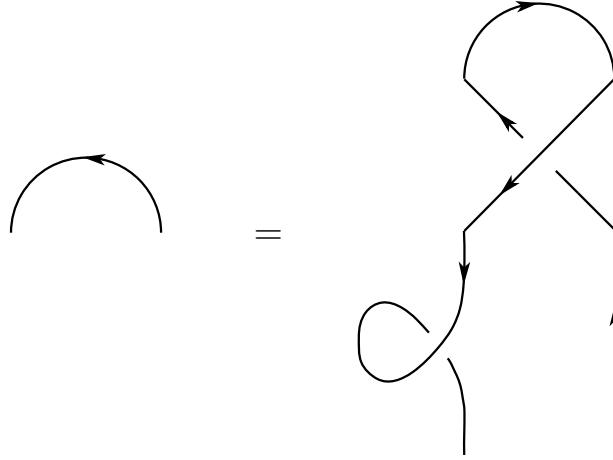

FIGURE 19. Reverse cap in RT generators

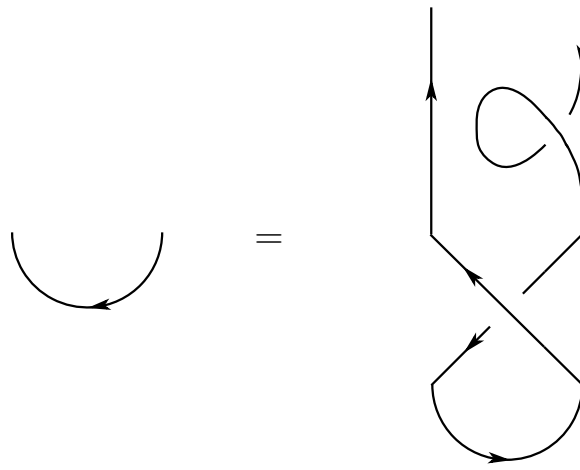

FIGURE 20. Reverse cup in RT generators

(f) Move the positive curl past a X -crossing, i.e.

$$X_{V,W}^{\pm} \circ (\downarrow_V \otimes \phi_W) = (\phi_W \otimes \downarrow_V) \circ X_{V,W}^{\pm}$$

(g) Reidemeister 2 (bis): The inverse of $Z_{V,W}^{\pm}$ is $Y_{W,V}^{\mp}$, expressed in RT generators as in figure 17. Explicitly:

$$Z_{V,W}^{\pm} = ((\cap_W \otimes \downarrow_V \otimes \uparrow_W) \circ (\uparrow_W \otimes X_{V,W}^{\mp} \otimes \uparrow_W) \circ (\uparrow_W \otimes \downarrow_V \otimes \cup_W))^{-1}$$

(h)

$$\phi_V^2 = (\cap_V \otimes \downarrow_V) \circ (\uparrow_V \otimes X_{V,V}^+) \circ (Z_{V,V}^+ \otimes \downarrow_V) \circ (\cup_V \otimes \downarrow_V)$$

(i) Crossing a coupon as in figure 12.

(j) Crossing a coupon as in figure 13.

(k) *Twisting a coupon as in figure 14.*

The main theorem of this section is:

Theorem 2.28. *The pair $(G_c^{G,RT}, R_c^{G,RT})$ is also a presentation of \mathcal{T}_c^G .*

Proof. Let $\mathcal{W}_c^{G,RT}$ denote the set of admissible RT-words (in the sense of week 46) and let $\mathcal{W}_c^{G,RM}$ denote the set of admissible RM-words. Recall that (in the notation of week 46) $F(G_c^{RM})$ denotes the free monoidal category on the generator set G_c^{RM} , and similarly $F(G_c^{RT})$ denotes the free monoidal category with generators G_c^{RT} .

We denote by $\mathcal{T}_c^{G,RT}$ the strict monoidal category given by the pair $(G_c^{G,RT}, R_c^{G,RT})$. We want to show that this category is isomorphic to \mathcal{T}_c^G via a strict tensor functor.

Step 1: The relations $R_c^{G,RT}$ are true in \mathcal{T}_c^G , in particular we have a strict monomial functor $\gamma : \mathcal{T}_c^{G,RT} \rightarrow \mathcal{T}_c^G$ (by the discussion in the syllabus of week 46). Moreover γ is surjective. These assertions are easy verifications, by drawing the corresponding generic diagrams and checking that the relations indeed represent topologically true statements. The surjectivity follows from Proposition 2.26.

We will now construct maps according to the following diagram. The maps $A, B, \alpha, \beta, \gamma, \rho$ in this diagram are the morphism components of strict tensor functors which are themselves also denoted by $A, B, \alpha, \beta, \gamma, \rho$ respectively. Observe that the isomorphism ρ was obtained in Theorem 2.24.

$$\begin{array}{ccc}
 \mathcal{W}_c^{G,RM} & \begin{array}{c} \xrightarrow{a} \\ \xleftarrow{b} \end{array} & \mathcal{W}_c^{G,RT} \\
 \downarrow & & \downarrow \\
 \text{Hom}(F(G_c^{RM})) & \begin{array}{c} \xrightarrow{A} \\ \xleftarrow{B} \end{array} & \text{Hom}(F(G_c^{RT})) \\
 \downarrow & & \downarrow \pi \\
 \text{Hom}(\mathcal{T}_c^{G,RM}) & \begin{array}{c} \xrightarrow{\alpha} \\ \xleftarrow{\beta} \end{array} & \text{Hom}(\mathcal{T}_c^{G,RT}) \\
 \downarrow \simeq \rho & \swarrow \gamma & \\
 \text{Hom}(\mathcal{T}_c^G) & &
 \end{array}$$

Step 2: Define a map $a : \mathcal{W}_c^{G,RM} \rightarrow \mathcal{W}_c^{G,RT}$ by expressing the RM-generators in RT-generators as explained in the proof of Proposition 2.26, and extending to this to a map sending elementary RM-morphisms to admissible RT-words (elements of $\mathcal{W}_c^{G,RT}$) in the obvious way. Finally we define a by using substituting the elementary RM-morphisms of an admissible RM-word by the corresponding admissible RT-words using the above map.

By a similar procedure we define a map $b : \mathcal{W}_c^{G,RT} \rightarrow \mathcal{W}_c^{G,RM}$ corresponding to the map $b : G_c^{G,RT} \rightarrow G_c^{G,RM}$ determined by saying that it is identical on the X, Z, \cap, \cup generators and the elementary \mathcal{C} -colored graphs, and

$$(2.16) \quad b(\phi_V) = (\cap_V \otimes \downarrow_V) \circ (\uparrow_V \otimes X_{V,V}^+) \circ (\cup_V^- \otimes \downarrow_V)$$

$$(2.17) \quad b(\phi'_V) = (\cap_V \otimes \downarrow_V) \circ (\uparrow_V \otimes X_{V,V}^-) \circ (\cup_V^- \otimes \downarrow_V)$$

This obviously defines strict monoidal functors $A : F(G_c^{RM}) \rightarrow F(G_c^{RT})$ and $B : F(G_c^{RT}) \rightarrow F(G_c^{RM})$.

Step 3. The strict monoidal functor $\bar{B} : F(G_c^{RT}) \rightarrow \mathcal{T}_c^{G, RM}$ (obtained by composing B with the canonical tensor functor from $F(G_c^{RM})$ to $\mathcal{T}_c^{G, RM}$) descends to a surjective (on morphisms) strict tensor functor $\beta : \mathcal{T}_c^{G, RT} \rightarrow \mathcal{T}_c^{G, RM}$ such that $\gamma = \rho \circ \beta$.

This is true because $\gamma \circ \pi = \rho \circ \bar{B}$, as one easily checks by computing the images of the RT-generators on both sides. The surjectivity of β now follows from Step 1.

Step 4. The strict monoidal functor $\bar{A} : F(G_c^{RM}) \rightarrow \mathcal{T}_c^{G, RT}$ (obtained by composing A with the canonical tensor functor from $F(G_c^{RT})$ to $\mathcal{T}_c^{G, RT}$) descends to a strict tensor functor $\alpha : \mathcal{T}_c^{G, RM} \rightarrow \mathcal{T}_c^{G, RT}$.

This step is the core of the proof. It is not hard, but it requires a lot of verifications since there are many RM-relations, and we need to verify that all RM-relations give rise to RT-equivalences if we apply the map a to both sides of the RM-relation. The proofs can be given in an entirely pictorial fashion. We work in $\mathcal{W}_c^{G, RT}$, representing the words by diagrams, and we transform the diagrams according to the RT-equivalences (and already established RM-relations, so that we acquire more power as we are progressing through the proof).

We refer the interested reader to [2, Chapter 1, paragraph 4.4–4.9].

Step 5. The strict tensor functors α and β are inverse isomorphisms.

We have seen in Step 3 that β is surjective on morphisms. Hence it suffices to show that $\alpha \circ \beta = \text{id}$. In other words, we need to show that we have $a(b(g)) \equiv_{RT} g$ for all $g \in G_c^{R, RT}$.

This is trivial for all generators except for ϕ_V and ϕ'_V . By $R_c^{G, RT}[(e)]$ it suffices to prove it for ϕ_V only. This is an easy verification, using $R_c^{G, RT}[(f)]$ and $R_c^{G, RT}[(h)]$. \square

REFERENCES

- [1] C. Kassel, M. Rosso, and V. Turaev, *Quantum groups and knot invariants*, Panoramas et synthèses **5**, Soc. Math. de France (1997)
- [2] V.G. Turaev, *Quantum invariants of Knots and 3-manifold invariants*, Walter de Gruyter (1994).